



COMMONWEALTH OF PENNSYLVANIA
DEPARTMENT OF GENERAL SERVICES
HARRISBURG

Thank you for responding to the Commonwealth of Pennsylvania's Solicitation for Proposal (SFP) #94685 to lease to the Commonwealth 19,132 usable square feet of office space in Allegheny County, Pennsylvania. The space will be occupied by the Pennsylvania Department of Human Services.

The availability of private and/or public parking should be included in proposals.

Enclosed you will find SFP #94685 which includes 5 appendices, including the Commonwealth's Standard Lease Terms & Conditions.

This SFP contains information that will guide you in preparing a proposal submission on the enclosed forms. **To be considered, all proposals must be submitted utilizing the forms identified in Appendix B.** Proposals must be addressed to the Bureau of Real Estate, Room 503, North Office Building, Harrisburg, Pennsylvania 17125 and received by the Commonwealth of Pennsylvania by 3:00 P.M., February 27, 2015.

PROPOSALS WILL NOT BE ACCEPTED AFTER THIS TIME.

PLEASE NOTE THAT SFPs ARE NOT PUBLIC BID OPENINGS.

Your proposal must be submitted in a sealed envelope. THE ENVELOPE MUST BE MARKED WITH SFP#94685, AGENCY'S NAME, REAL ESTATE COORDINATOR'S NAME, SQUARE FOOTAGE, AND DUE DATE. THIS INFORMATION MUST ALSO BE SHOWN ON THE OUTSIDE OF ANY COURIER OR MAILING ENVELOPE. Do not submit a proposal for another SFP in the same envelope with your proposal for this particular SFP. Please be advised that this is a proposal solicitation process. The Commonwealth of Pennsylvania reserves the right to reject any or all offers, waive any defect or negotiate for better terms.

This solicitation reflects material changes which have been made to the Commonwealth lease solicitation process. Payment of prevailing wages is now a requirement of the Commonwealth's leasing program when a proposer offers to construct a new facility or substantially rehabilitate an existing facility. Specific information on the payment of prevailing wages requirement can be found on Page 5 of this SFP. There are also new requirements concerning the Right to Know Law. Specific information on the disclosure of proposal contents can be found on Page 7 of this SFP.

Please be sure to carefully read the whole document. If you have any questions concerning the attached information, please contact Scott Shelton directly at (717) 787-5546 or via email at scshelton@pa.gov.

**503 North Office Building, Harrisburg, PA 17125
Telephone: 717-787-4394 FAX No: 717-783-0570**

SOLICITATION FOR PROPOSAL (SFP) # 94685

Pennsylvania Department of Human Services

Date of Issue:
December 30, 2015

Issuing Office:
Department of General Services
Bureau of Real Estate
Room 503 North Office Building
Harrisburg, Pennsylvania 17125
(717) 787-4394

Table of Contents

	<u>Pages</u>
I. General Information for the Proposer	4-9
II. Proposal Requirements	10-11
Appendix A	Lease Standard Terms and Conditions <i>(Attachment A of New Lease)</i>
Appendix B	Required Documents
Appendix C	Building Specifications <i>(Attachments B and C of New Lease)</i>
Appendix D	Commonwealth Requirements
Appendix E	Geographic Boundaries

I. GENERAL INFORMATION FOR THE PROPOSER

PURPOSE

The purpose of this Solicitation for Proposal (SFP) is to obtain proposals to provide 19,132 net usable square feet of office space, to house approximately one hundred and thirty-two (132) Commonwealth employees. The space must be located within the following boundaries: Northern Boundary is the Allegheny River, Butler Street at Route 8, Butler Street to Heron Ave., Heron Ave to Robinson St Ext/Robinson St, Robinson St. to Route 30, Route 30/I-376 is the South Boundary, Route 30/I-376 to Route 8, Route 8 to Wood St., Wood St./Oakwood to Blackadore Ave, Blackadore Ave to Mt. Caramel Rd., Mt. Caramel Rd to Tyler Rd., Tyler Rd. to Lincoln Rd., Lincoln Rd. to Nadine Rd., Nadine Rd. to Allegheny River Blvd.. Proposals which offer space outside of these boundaries cannot be considered for award of the lease.

Proposers should prepare and submit proposals to be considered by the Commonwealth of Pennsylvania (Commonwealth) for a ten (10)-year lease (with options for two (2) five (5) year renewal terms) to be occupied by the Pennsylvania Department of Human Services.

The availability of private and/or public parking should be included in proposals.

ISSUING OFFICE

The Department of General Services (DGS), Bureau of Real Estate, issues this SFP for the Commonwealth. The point of contact is:

Scott Shelton
Department of General Services
Bureau of Real Estate
Room 503 North Office Building
Harrisburg, PA 17125
(717) 787-5546

Only the DGS Bureau of Real Estate is authorized to negotiate the terms and conditions of a proposed lease agreement. No understanding shall be binding upon the Commonwealth until all of the following occur: (1) the parties' understanding has been reduced to a formal written lease agreement; (2) the lease agreement has received all necessary Commonwealth approvals, including, but not limited to, the approval of the Board of Commissioners of Public Grounds and Buildings; (3) the lease agreement has been signed by the Secretary of the Department of General Services, and (4) the fully executed lease agreement has been delivered by DGS to the selected proposer.

SCOPE

This SFP contains instructions governing the proposals to be submitted and the material to be included therein; a description of the services to be provided; requirements that must be met to be eligible for consideration; and other requirements to be met by each interested party.

RESPONSE DATE

To be considered, proposals must arrive at the issuing office, on or before the date and time specified in the cover letter. Proposals must be returned in the envelope provided with the proposal packet. **ALL LATE PROPOSALS SHALL BE REJECTED.**

NOTICE TO PROPOSERS OF PREVAILING WAGE REQUIREMENTS

To the extent that a proposer offers to construct a new facility, to substantially rehabilitate an existing facility, or to substantially alter an existing facility in accordance with Commonwealth agency specifications/drawings, and the construction/substantial rehabilitation/substantial alterations will have a total estimated cost that exceeds \$25,000, the following prevailing wage requirements shall be included in the lease. “Substantial rehabilitation” is the conversion or adaptation of an existing facility into a safe, structurally sound building, by gutting and extensive re-construction, to make the building suitable for use by the Commonwealth agency. As a guideline, if the building foundations, building shell (outer walls, interior support walls or roof) or major building systems (HVAC, plumbing, electrical) are substantially altered or replaced, it is substantial rehabilitation. “Substantial alterations” are those alterations to an existing facility by the lessor in accordance with Commonwealth agency specifications/plans/drawings where final plans, drawings and specifications must be reviewed and approved by the Commonwealth agency. These terms do not include cosmetic improvements, routine maintenance, minor non-structural alterations and upgrades.

The lease shall require the lessor and lessor’s contractor(s) to pay no less than the wage rates as issued by the Secretary of the Pennsylvania Department of Labor and Industry for each craft or classification of all workers needed to perform the contract(s) for the construction/substantial rehabilitation/substantial alterations of the facility. The construction/substantial rehabilitation/substantial alterations required by the lease will be subject to the provisions, conditions, duties, requirements, remedies and penalties of the Pennsylvania Prevailing Wage Act, 43 P.S. § 165-1 *et seq.* The prevailing minimum wage predetermination, as issued by the Secretary of Labor and Industry, shall be attached to the lease and made a part of the lease. No workers may be employed in the construction/substantial rehabilitation/substantial alterations, except in accordance with the classifications in the prevailing minimum wage predetermination of the Secretary of Labor and Industry. If additional or different classifications are necessary, the lessor shall request the Department of General Services to petition the Secretary of Labor and Industry for rates for additional or different classifications.

The rent requested by proposers offering to construct a new facility or to substantially rehabilitate an existing facility or to make substantial alterations must take into consideration the requirement of the lessor and lessor’s contractor(s) to pay no less than the prevailing wage rates issued by the Secretary of Labor and Industry.

In order to view the current prevailing wages for each craft or classification of workers needed to perform the contract(s) for the construction/substantial rehabilitation/substantial alterations of the leased facility for the locality where the facility will be constructed/substantially rehabilitated go to http://www.dli.state.pa.us/landi/li_apps/requestPW.asp and request the prevailing wages. These are the applicable wage rates **provided** a lease is negotiated and fully executed within 120 days of the proposal response date. In the event the lease is not fully executed within this 120 day period, it will be necessary to request and obtain new, current prevailing minimum wage rates from the Secretary of Labor and Industry that the lessor or lessor’s contractors must pay to those employees involved in the construction/improvement/alteration of the leased facility.

Proposals must include a statement indicating whether or not the rent is based upon the requirement to pay prevailing wages.

If, after receipt of proposals, the DGS determines that the lessor and lessor's contractor(s) should pay the prevailing minimum wage rates when the lessor's proposal did not include consideration of this requirement, DGS may give the proposer the opportunity to revise its offered rental amounts to include allowance for payment of prevailing wages. When such a determination is made, the lease shall require, or be amended to require, the lessor and lessor's contractor(s) to pay the prevailing minimum wage rates as issued by the Secretary of the Pennsylvania Department of Labor and Industry. If this occurs, the lessor and DGS shall negotiate either an increase in the rental rate or the amount of a one-time payment to cover the increase in cost as a result of including this requirement. The lease will be subject to the provisions, conditions, duties, requirements, remedies and penalties of the Pennsylvania Prevailing Wage Act, 43 P.S. § 165-1 *et seq.*

SUBMISSION OF PROPOSALS

To be considered, interested parties must submit a complete response to this SFP, using the format provided in the "Proposal Requirement" section of this document. An interested party will make no other distribution of the proposal. An official who is authorized to bind the interested party to its provisions must sign the proposal. For this SFP, the conditions of the proposal must remain valid for at least sixty (60) days from the date specified in the cover letter. **Moreover, the conditions of the selected proposal will become contractual obligations if a contract is entered into with the Commonwealth.**

A complete proposal package is necessary for evaluation of your proposal. Failure to include any of the required information or forms will delay evaluation of your proposal and may, at the Commonwealth's sole discretion, result in the rejection of your proposal.

The Commonwealth now allows alternate responses for one solicitation. In order to be considered as a complying submission, a proposal must initially adhere strictly to the solicitation specifications in all material regards. However, in addition to this component, a proposer may, at the proposer's discretion, submit one or more alternate proposals that vary from the specifications. In particular, the proposer may, by way of example, propose alternate finishes or spatial layouts that allow the proposer to submit a more competitive price proposal. The proposal must clearly label the primary proposal, and all alternates, and a clear breakdown of the price differentials should be delineated. DGS will consider and evaluate the primary and all alternate proposals at its sole discretion.

TYPE OF AGREEMENT

The selected party will be expected to enter into a lease agreement in substantially the same form as the sample lease which is attached as **APPENDIX A** of this SFP. **The terms and conditions of this SFP and the selected party's proposal will be incorporated into the lease by reference.**

REJECTION OF PROPOSALS

The Commonwealth reserves the right to reject any and/or all proposals received as a result of this request, or to negotiate separately with competing contractors. If, in the opinion of the Commonwealth, contract negotiations with the selected party cannot be concluded **within 60 days following the selected party's receipt of a draft lease agreement**, the Commonwealth

may at its sole discretion, immediately discontinue negotiations with the selected party and commence negotiations with any other interested party.

INCURRING COSTS

The Commonwealth is not liable for any costs incurred by interested parties related to the preparation of their proposals for this SFP.

ECONOMY OF PREPARATION

Proposals should be prepared simply and economically, providing a straightforward, concise description of the interested party's ability to meet the requirements of the SFP.

ORAL PRESENTATION

An interested party that submits a proposal may be required to make an oral presentation of its development plan to DGS.

AMENDMENT TO THE SFP

If it becomes necessary to revise any part of this SFP, an amendment will be issued to all interested parties who received the original SFP. **For any interested party who downloads the SFP from the DGS website, it will be that party's responsibility to check the website for amendments to the SFP prior to the submission of its proposal.**

SELECTED PARTY RESPONSIBILITIES

The selected party will be required to assume responsibility for all services offered in the proposal whether or not the selected party actually performs them. Further, the Commonwealth will consider the selected party to be the sole point of contact with regard to contractual matters.

DISCLOSURE OF PROPOSAL CONTENTS

- **Confidential Information.** The Commonwealth is not requesting, and does not require, confidential proprietary information or trade secrets to be included as part of proposers' submissions in order to evaluate proposals submitted in response to this SFP. Accordingly, except as provided herein, proposers should not label proposal submissions as confidential or proprietary or trade secret protected. Any proposer who determines that it must divulge such information as part of its proposal must submit the signed written statement described in subsection c.(2) below and must additionally provide a redacted version of its proposal, which removes only the confidential proprietary information and trade secrets, for required public disclosure purposes.
- **Commonwealth Use.** All material submitted with the proposal shall be considered the property of the Commonwealth of Pennsylvania and may be returned only at the issuing office's option. The Commonwealth has the right to use any or all ideas not protected by intellectual property rights that are presented in any proposal regardless of whether the proposal becomes part of a lease. Notwithstanding any proposer copyright designations contained on proposals, the Commonwealth shall have the right to make copies and distribute proposals internally and to comply with public record or other disclosure

requirements under the provisions of any Commonwealth or United States statute or regulation, or rule or order of any court of competent jurisdiction.

- **Public Disclosure.** Public records requests for proposals are governed by and shall be handled in the following manner:

After the award of a lease pursuant to this SFP, all proposal submissions are subject to disclosure in response to a request for public records made under the Pennsylvania Right-to-Know-Law, 65 P.S. § 67.101, et seq., commencing January 1, 2009. If a proposal submission contains confidential proprietary information or trade secrets, a signed written statement to this effect must be provided with the submission in accordance with 65 P.S. § 67.707(b) for the information to be considered exempt from disclosure under 65 P.S. § 67.708(b)(11).

NEWS RELEASES

News releases pertaining to this project will be made in coordination with the issuing office, and subject to Commonwealth approval.

FACILITY ACCESS

Consistent with safety and operational factors, the selected proposer will provide the Commonwealth unlimited access to the leased premises during the construction period.

PENNSYLVANIA STATE SALES AND USE TAX

The proposed facility is subject to all applicable Pennsylvania Sales and Use Tax legislation. There is no special tax exemption for this project.

ORDER OF PRECEDENCE

If any discrepancies in interpretation arise, the terms of the Lease Agreement are the first point of reference, the SFP and all attachments are the second, and the Proposal is the third.

II. PROPOSAL REQUIREMENTS

INTRODUCTION

This section contains instructions governing the proposals to be submitted and the material to be included in the proposal. The proposal shall be submitted in the format delineated below.

It is the obligation of the proposer to become fully cognizant of all factors relevant to the site including, but not limited to, existing and surrounding zoning and zoning requirements, physical characteristics and conditions of the site and improvements, asbestos and environmental hazards, adequacy of public facilities, utility services, legal restrictions, and all other information relating to legal requirements, land-use planning, or design requirements and restraints.

REQUIRED DOCUMENTS

The following required documents **must** be completed accurately and submitted as part of your proposal (**APPENDIX B**):

1. GSRE -19 Proposal to Lease Space to the Commonwealth

As indicated on GSRE – 19, certain required services should be included as part of your proposal. The required services are, but are not limited, to the following:

- a. All Utilities
 - b. Janitorial Services and Supplies (please check the janitorial schedule included in the Agency Specifications attached to this SFP.)
 - c. Trash Removal
 - d. Snow and Ice Removal
 - e. Sewer and Water
 - f. Lawn and Shrub Care
 - g. Acquisition of the Site
 - h. Permitting
 - i. All Professional Fees
 - j. Financing
 - k. Building Construction
 - l. Real Estate Taxes
 - m. Insurance
- 2. GSRE - 6 Lessor Identity Disclosure**
- 3. GSRE - 47 Agency Agreement/Limited Agent Authority**
- 4. GSRE - 42M Contractor Responsibility Certification**
- 5. GSRE - 54 Notice - Bureau of Real Estate is Sole Agent for Commonwealth**
- 6. GSRE – 63 Acknowledgment/Usable Area Definition**
- 7. GSRE – 64 Consent to Release or Obtain Information and Contact Professional References**
- 8. Prevailing Wage Pre-determination issued by the Department of Labor & Industry**

In addition to the required standard forms, a graphic schedule and narrative on the schedule through the design and construction phases of the project is required. This schedule will be used to complete **Paragraph 18** of the draft lease agreement (APPENDIX A), and will include how

the proposer plans to meet its proposed final completion date. The schedule for the development of the site should include but are not limited to:

- Test Fit
- Site Control
- Code and Building Permit Approvals
- Construction
- Utility Disconnect/Reconnect

ADDITIONAL INFORMATION

In order to assist with the evaluation of your proposal, the following should be included with your proposal package:

- Drawings - Site Plan(s), Floor Plans, Elevations and Building Sections.
- Photographs - Please mark photographs for easy reference .
- Any documentation the proposer determines to be necessary to explain the proposal.

APPENDIX A

**LEASE STANDARD TERMS AND
CONDITIONS**

Lease Standard Terms and Conditions

I. Definitions:

The following terms shall be defined as follows:

1. **Additional Rent** – Adjustable rent, up to a maximum annual amount of 5% of the preceding year's Additional Rent, shall be made to cover increases or decreases in the costs of real estate taxes, utilities, water, sewer, trash removal, insurance and janitorial services. The actual amount of the adjustment (increase or decrease) shall be determined by annually applying the CPI-U, NE Cities Index (Consumer Price Index for all Urban Consumers, Northeast Cities index, all items, as found in table 11 of the CPI Detailed Report published by the U.S. Department of Labor, Bureau of Labor Statistics) to the amount of the Additional Rent for the preceding year of the Lease. The Additional Rent shall not be adjusted to reflect actual costs incurred by Lessor during the term of this Lease, nor shall the amounts paid as Additional Rent be adjusted to reflect changes in the above Lessor costs.
2. **Base Rent** – Negotiated rent, not including Additional Rent, due to Lessor.
3. **Commencement Date** – The first day of the calendar month after the date the Premises are accepted for occupancy by the Lessee, as memorialized by the Using Agency's completion and execution of an "Acceptance of Leased Premises and/or Renovations Inspection Report" (GSRE-42-N(08-13), a sample of which is attached hereto as Exhibit 1.
4. **Common Areas** – Any space in a building affording common use for all tenants, with the exception of vertical penetrations (elevator shafts, flues, vertical ducting). Common Areas shall include but not be limited to building and elevator lobbies, corridors including but not limited to those leading from the elevator to the tenant space, restrooms, building break rooms, building conference rooms, janitorial closets and storage rooms.
5. **Commonwealth of Pennsylvania Standard Building Specifications** – The Commonwealth's standards for building, renovating, maintaining, operating, and repairing the Premises as set forth on Attachment B.
6. **Commonwealth of Pennsylvania Using Agency Building Specifications** – The Commonwealth of Pennsylvania's standards for building, renovating, maintaining, operating, and repairing the Premises as set forth on Attachment C. Items referenced in these specifications are specific to the Using Agency and may not apply to all Commonwealth leases.
7. **Consent Form** – A document signed by the Lessor, and approved by DGS/BRE, that states that the Lessor is aware of the Leasehold Improvement(s) requested by the Lessee and that the Lessor is allowing the Lessee to complete those Leasehold Improvements at Lessee's cost, as set forth on Exhibit 2.
8. **CPI** – The United States Bureau of Labor, Statistics, Consumer Price Index, all Urban Consumers, Northeast Cities Index, all items, as found in Table 11 of the CPI Detailed Report published by the U.S. Department of Labor, Bureau of Labor Statistics. The CPI-U, NE Cities Index reported four months prior to each anniversary of the Commencement Date shall be used to determine the amount of the adjustment to the Additional Rental Rate.
9. **DGS/BRE** – Department of General Services, Bureau of Real Estate.
10. **Execution Date** – Shall be the date the lease is signed by the Secretary of General Services after all other approvals have been obtained and shall be entered on the appropriate line of the first page of the Lease Cover Sheet.
11. **Expiration Date** – Shall be the date the lease is set to expire as identified on the Lease Cover Sheet.
12. **Initial Term** – Shall be the number of years identified on the Lease Cover Sheet that begins on the Commencement Date.

13. **Lease** – Is collectively comprised of all of the documents as identified on the Lease Cover Sheet.
14. **Lease Cover Sheet** – Shall include, but not be limited to, the name of the Lessor, the name of the Lessee, the Rent, the Initial Term, and the Net Usable Square Feet. Shall be the cover page to the Lease.
15. **Lease Amendment** – Written agreement between Lessor and Lessee which modifies the Lease.
16. **Leasehold Improvements** – Additions, alterations or improvements to the Premises and/or Common Areas, which occur after the Commencement Date.
17. **Lease Year** – Each successive twelve (12) month period starting on the Commencement Date.
18. **Lessee** – The Commonwealth of Pennsylvania, acting through the Department of General Services, on behalf of the Using Agency identified on the Lease Cover Sheet.
19. **Lessor** – Title owner that has the right to lease the Premises to Lessee.
20. **Net Usable Square Feet** – Shall be the number of square feet identified on the Lease Cover Sheet. Measurement computed by measuring the area to be used by the Using Agency from the inside perimeter walls surrounding this area, excluding stairwells, elevator shafts, public restrooms not within the leased space, mechanical and building equipment rooms and any area used by the Lessor. Lessor agrees that in a multiple tenant facility, if the building configuration requires a common access corridor serving more than one Commonwealth program area entrances, then that corridor space shall not be considered part of the net usable square footage.
21. **Normal Business Hours** – Monday through Friday 7:00 a.m. - 7:00 p.m. unless otherwise specified on the Lease Cover Sheet.
22. **Pre-Construction Meeting** – Meeting held between the Lessee, including but not limited to its agents, employees, licensees or invitees, and Lessor, including but not limited to its agents, contractors, subcontractors, employees, licensees, or invitees, after a lease or amendment is fully executed, but prior to any Work commencing on the leased Premises.
This meeting is intended to review and discuss final plans, timelines and concerns of all parties involved.
23. **Premises** -- The property or part of the property, more specifically described on the plan and/or specifications attached to this Lease and consisting of the amount of net usable square feet identified on the Lease Cover Sheet, together with Common Areas. Lessor and Lessee agree that the plan and/or specifications are subject to adjustment as agreed upon by the Lessor and Lessee, and in the event that there are adjustments to the plan and/or specifications, the Lessor and Lessee agree to replace any documents related hereto with a revised version of such document in order to accurately depict the Premises.
24. **Rent** – The monthly payment to Lessor by Lessee for use of the Premises, as determined by multiplying the amount of Net Usable Square Feet set forth on the Lease Cover Sheet by the Rental Rate. Rent shall be paid in equal monthly installments.
25. **Rental Rate** – The sum of the Base Rent and the Additional Rent, as set forth on the Lease Cover Sheet.
26. **Termination Date** – shall be the date the Lease is terminated with prior notification from the Lessee to the Lessor.
27. **Using Agency** – The Commonwealth of Pennsylvania Agency which occupies the leased Premises and is identified on the Lease Cover Sheet.
28. **Work** – Consists of the construction and renovation of the Premises substantially in accordance with all plans and specifications set forth on **Attachment B** and **Attachment C**.

II. Background:

1. By the *Act of April 9, 1929, P.L. 177, as amended, 71 P.S. Section 632(d)*, the Department of General Services is, with the approval of the Board of Commissioners of Public Grounds and Buildings, authorized and empowered to rent proper and adequate offices, rooms or accommodations for any department, board or commission which cannot be properly and adequately accommodated with offices, rooms and accommodations in the Capitol buildings.
2. Lessee desires to lease the net usable square footage, as defined on the Lease Cover Sheet, from Lessor for use by the Using Agency, upon the terms and conditions set forth in the Lease.
3. Lessor owns or has the right to lease the Premises to Lessee.
4. In consideration of the following mutual promises and intending to be legally bound hereby, Lessor and Lessee agree to the following Terms and Conditions:

III. Terms and Conditions:

1. **Incorporation of Definitions and Background Clauses.** Any and all background clauses, definitions and Exhibits are incorporated into the Lease by reference.
2. **Premises.**
 - a. Lessor leases the Premises to Lessee for use and occupancy by the Using Agency, and Lessee leases the Premises from Lessor for use and occupancy by the Using Agency.
 - b. The Net Usable Square Feet shall be subject to verification, in accordance with the procedure set forth in Paragraph 17 "Completion" below. Lessee shall have the right to use any space within the Premises in excess of the Net Usable Square Feet without the requirement to pay any additional rent, costs or charges. In the event the actual net usable square feet is less than the Net Usable Square Feet, then, Lessee shall have the right to (i) reduce the amount of Net Usable Square Feet and pay for the reduced amount of the Net Usable Square Feet; or (ii) terminate the Lease without liability for any costs or future rent, if Lessee determines, in its sole judgment, that the actual amount of Net Usable Square Feet provided is insufficient to meet Lessee's needs.
 - c. Lessor shall lease the number of parking spaces to Lessee as referenced on the Lease Cover Sheet. Lessor agrees that these parking spaces are included in the Rental Rate for the Premises as set forth on the Lease Cover Sheet. Lessor agrees that there is no additional payment due for these parking spaces.
3. **Term.** The Initial Term of the Lease shall be the number of years referenced on the Lease Cover Sheet. The Initial Term shall begin on the Commencement Date and end, without the necessity of notice from either party to the other, on the expiration of the number of years in the term, subject to the renewal options set forth on the Lease Cover Sheet.
4. **Rent.**
 - a. Lessee shall pay Lessor Rent for the use and occupancy of the Premises.
 - b. The Rental Rate for all succeeding Lease Years, including any option terms, shall be calculated by Lessee, without the necessity of a request from Lessor, as follows:
 - i. Multiply the percentage of change in the CPI by the Additional Rent for the then current Lease Year. The resulting product will equal the amount of increase or decrease in the Additional Rent for the succeeding Lease Year.
 - ii. The amount of the increase or decrease shall be applied to the Additional Rental Rate for the current Lease Year, to arrive at the Additional Rent for the succeeding Lease Year. The

adjusted Additional Rent will then be added to the Base Rent to calculate the Rental Rate for the succeeding Lease Year.

5. **Rent Payments.**

- a. Lessee shall make Rent payments electronically through Automated Clearing House (“ACH”). Lessor shall complete the Pennsylvania Electronic Payment Program (PEPP) Enrollment Form, which is available at: <https://www.vendorregistration.state.pa.us/cvmu/paper/Forms/ACH-EFTenrollmentform.pdf>.
 - i. No later than 10 days after Lessor’s receipt of the executed Lease, Lessor shall submit the completed PEPP Enrollment Form by fax to the Commonwealth of Pennsylvania, Vendor Data Management Unit, Payable Service Center at 717-214-0140, or by mail to the Commonwealth of Pennsylvania, Office of Budget, Payable Services Center, 555 Walnut Street – 9th Floor, Harrisburg, PA 17101.
 - ii. It shall be the responsibility of the Lessor to ensure that the ACH information submitted is correct and to ensure the most current information is provided to the Vendor Data Management Unit throughout the term of the Lease. Failure to timely submit and maintain accurate and complete ACH information may result in delays in Rent payments.
 - iii. Lessor hereby acknowledges and agrees that failure to timely submit and maintain accurate and complete ACH information may result in delays in Rent.
- b. Lessee reserves the right, upon thirty (30) days prior written notice to Lessor, to offset future Rent payments to recover any prior Rent overpayment made by Lessee to Lessor.
- c. Lessor agrees that Lessee may offset the amount of any state tax liability or other obligation of Lessor or its subsidiaries to the Commonwealth against any payments due the Lessor under any contract with the Commonwealth.

6. **Taxes.** Lessor shall pay, in a timely manner, all real estate taxes and municipal, general and special assessments and other taxes of any nature applicable to the Premises and the Common Areas, as well as the parking spaces subject to this Lease, directly to the taxing authority.

7. **Non-Appropriation/Cancellation.** It is understood and agreed between the parties hereto that if the governmental function for which the Premises are being leased, is abolished, limited, or restricted, by any Act of Legislature, including a failure of sufficient appropriation by the General Assembly to continue payment of the Rent or any other amount hereunder, or by Law of Congress, or by any Action taken under authority conferred by such acts or laws, or decision of court; then the Lessee shall have the right to cancel this Lease by giving one month's notice in writing. At the option of the parties, if they have agreed on the total costs of renovations prior to the execution of this Lease and the Lease is canceled pursuant to the provisions of this Paragraph, if the Agency's annual appropriations permit, Lessee shall reimburse Lessor for any unamortized costs of renovations performed by Lessor pursuant to this Lease at Lessee’s request, and which are peculiar to Lessee’s tenancy.

8. **Termination for Convenience.** In addition to any rights of termination already contained in the Lease, Lessee is hereby granted the right to terminate this Lease in accordance with this clause whenever the Lessee shall determine in its sole discretion that such termination is in the best interest of the Lessee. Lessee must provide at least six (6) months prior written notice to Lessor of the intended date of termination. Such termination date may not be prior to the expiration of at least fifty percent (50%) of the initial term of this Lease. In the event Lessee exercises this option to terminate for its convenience, Lessee shall pay Lessor a sum equivalent to three (3) months Base Rent as an early termination fee (early termination fee). In addition to the early termination fee, if the parties have agreed on the total costs of renovations prior to the execution of the Lease and the Lease is cancelled by Lessee pursuant to the provisions of this Paragraph, Lessee shall reimburse Lessor for any unamortized costs of renovations performed by Lessor pursuant to this Lease at Lessee’s request, and which are peculiar to Lessee’s tenancy.

Upon payment of the early termination fee, and any unamortized costs (if applicable), Lessor releases Lessee from any claims whatsoever, at such time or in the future, whether known or unknown, for any damages, consequences or liabilities associated with Lessee’s exercise of this Termination for Convenience clause.

9. **Options.** Lessee, at its sole discretion, shall have the option to renew this Lease for additional terms as identified on the Lease Cover Sheet. In order to exercise an option, Lessee must give Lessor three (3) months' prior written notice before the expiration of the then current term of this Lease. The Rental Rate for each option term shall be calculated by adding the Additional Rent to the Base Rent for the option term.
10. **Holdover/Termination.** Should Lessee holdover in possession after the expiration of the Initial Term of this Lease (without exercising any option to renew), or after the expiration of any renewal term (without exercising any remaining option to renew), such holding over shall not be deemed to extend the term of this Lease or any renewal term, but the tenancy thereafter shall continue from month to month, subject to the covenants and conditions of this Lease, until either party shall give the other three (3) months' notice in writing of its intention to terminate the tenancy. During any such holdover periods, the Base Rent will remain the same, for a period of three (3) months, as it was prior to the expiration of the term. Effective on the first day of the fourth month of any holdover period, the Lessee shall pay the amount of the Base Rent specified for the Option period as identified on the Lease Cover Sheet.
11. **Lessor's Duty to Mitigate Damages.** In the event Lessee abandons the Premises prior to the end of the then-current lease term, Lessor shall have an affirmative duty to proceed in good faith and with due diligence to make reasonable efforts to mitigate its damages and prevent further loss.
12. **Lessee's Alteration Rights.** For the life of the Lease, the Lessee must be offered the option to upgrade existing space for operational use, or to make additional alterations and renovations to the facility. In situations when the Lessor pays the upfront costs for the renovations or upgrades to the existing space, Lessor and Lessee hereby agree and acknowledge that the Lessee will reimburse Lessor.
13. **Utilities**
 - a. Lessor shall, at its sole cost and in return for Rent paid by Lessee pursuant to this Lease, provide, maintain, and pay the costs and periodic charges for, the following:
 - i. Heat, ventilation and air conditioning ("HVAC") for the Premises and all Common Areas in accordance with the standards set forth in **Attachment B**;
 - ii. All energy and utilities provided, used and consumed on the Premises and the Common Areas, including but not limited to gas, oil, electric, steam, water and sewer; except usage charges for telephone, CATV, internet and other communication services utilized by Lessee, which shall be arranged for and paid by Lessee;
 - iii. Hot and cold water to the Premises and the Common Areas (including restrooms within or serving the Premises); and
 - iv. Passenger and freight elevator services (including loading dock access and use) for access within, to and from the Premises. Lessor shall make no change in the elevator service provided to Lessee after the Commencement Date, without the Lessee's prior written consent.
 - b. Lessor shall, at its sole cost and in return for Rent paid by Lessee, provide access and consent to install or connect telecommunications cabling and equipment, including but not limited to telephone, CATV, high speed data transmission and internet connectivity on each floor of the Premises, occupied by Lessee, Lessor shall coordinate with the Using Agency designee and selected provider to arrange for such installation and connection through such infrastructure at Lessor's expense and in accordance with **Attachment B** and **Attachment C**. Additional changes or upgrades to the voice and data system after the initial scope of work is completed will be at the Lessee's expense and Lessor will provide access and consent to install.
 - i. The amount of Rent presumes a normal work week and hours for the Using Agency employees of Monday through Friday, from 7:00 A.M. to 7:00 P.M., unless otherwise specified in **Attachment C**. Lessee shall have the right to use the Premises seven days a week, twenty-four hours a day.
 - c. All other utility services, and elevator service, shall be maintained to the Premises and the Common Areas at the same level of service during all hours as during normal business hours, without additional cost to Lessee.

14. **Services.**

- a. *Ice and Snow Removal.* Lessor is responsible for snow and ice removal of sidewalks and parking areas within four hours after cessation of snow, sleet or icing weather. It is the Lessor's responsibility to correct all unsafe conditions relating to freezing and thawing. Lessor is responsible for the cleaning/repairing and maintenance of the roofs, gutters and awnings. Gutters should be cleaned on a regular basis and snow and sleet should be removed within four (4) hours of cessation.
- b. *Janitorial Services.* Lessor shall provide janitorial services as outlined in **Attachment B.**
- c. *Landscaping, Finish Grading, and Seeding.* Lessor shall furnish all labor, materials, and equipment as necessary to complete topsoil spreading, finish grading, sodding, seeding, and shrubbery planting as required to produce a uniform, weed-free stand of grass and acceptable landscaping. Lessor is responsible for maintaining shrubs, grass, including but not limited to mowing, and landscaping for the life of the lease.
- d. *Trash Dumpster/Trash Cans.* Lessor shall provide a designated trash area adjacent to the facility of a sufficient size to accommodate an appropriate commercial sized trash dumpster for solid waste. Lessor will maintain a waste management contract for the life of the lease. Individual trash cans capable of holding .5 gallons to 5 gallons and recycle cans capable of holding up to 5 gallons will be provided, collected and maintained for each workstation and office by the Lessor.
- e. *Recycling: Ordinances and Regulation.* Lessor shall:
 - i. Establish and maintain a separation and collection procedure for the removal of recyclable materials from the leased Premises;
 - ii. Collect, at a minimum, aluminum, high grade office paper, and corrugated paper;
 - iii. Comply with Act 101 of 1988 and any existing local codes and ordinances relating to the separation and disposal of recyclable materials;
 - iv. Provide suitable containers, dumpsters, etc., for collecting and storing recyclable materials;
 - v. Empty all recycling receptacles and remove recyclables to a designated area as often as necessary taking into consideration the volume of the recyclables and health concerns; and
 - vi. Assume all costs involved in collecting, storing and removing recyclables.
 - vii. Lessee reserves the right to identify those recyclable materials, generated from agency operations at the leased Premises, which Lessee desires to sell as serviceable property. Lessee reserves the right to dispose of such materials itself. When and if the Lessee exercises this discretion, the Lessor shall thereafter not be responsible for those materials selected by the Lessee for disposal by the Lessee.

15. **Maintenance and Repairs.** Lessor, at its sole cost and in return for Rent paid by Lessee, shall maintain, repair, replace and provide the continuous upkeep of the exterior of the building and all internal building systems, including but not limited to, electrical, lighting, plumbing, heating, ventilation equipment, air conditioning, elevators, escalators, and/or lifts, as set forth herein and as more specifically stated in **Attachment B** and **Attachment C.** Lessor shall not be responsible for damages caused by Lessee's negligence, or the negligence of Lessee's employees or agents. Service response times must be within twenty four (24) hours.

- a. *Maintenance Contracts.* Lessor shall secure maintenance service contracts, with certified service providers, for the life of the Lease, in the following areas: roof, HVAC systems, and elevators in compliance with **Attachment B.**
- b. *Elevators.*
 - i. All elevator equipment and systems shall be in operating order 24 hours per day and shall be serviced and maintained by the Lessor for the term of the Lease.

- ii. Lessor shall provide proof of semi-annual preventative maintenance and/or repairs to all elevator equipment and systems. The reports shall be provided in writing within 30 days of completion of any service and/or repairs to the DGS/BRE, Room 503, North Office Building, Harrisburg, PA 17125. The semi-annual maintenance will include, but is not limited to, the service of the following items: Hydraulics, cables, controllers.
 - iii. All elevator equipment and systems should be inspected bi-annually by a 3rd party certified inspector. If the elevator is found to be non-compliant, then an inspection will be completed by the Department of Labor and Industry. If the elevator is constructed prior to 2004 it must comply with 34 PA Code Chapter 7; if the elevator is constructed after 2004, the inspection must comply with ASME A17.1.
 - iv. Lessor shall notify Lessee at least one (1) day in advance of taking the elevator offline for maintenance and/or repair and give Lessee an estimated completion date of the maintenance and/or repair and when the elevator will be back online.
 - v. Lessor shall respond to an elevator entrapment within thirty (30) minutes of notification. If the Lessor fails to respond within thirty (30) minutes, the Lessee shall charge the Lessor Seventy-Five Dollars (\$75.00) for each failure to respond.
 - vi. Should more than three (3) elevator entrapments happen within six (6) months, then the Lessor shall have all elevator equipment and systems inspected and repaired within thirty (30) days of request by Lessee. Lessor shall provide Lessee a written report of the inspection and repair work of the elevator equipment and systems within five (5) business days of the completed inspection and within five (5) business days of the completed repair work.
 - vii. Lessor shall provide Lessee with a yearly preventative maintenance schedule for all elevator equipment and systems.
- c. *Lighting.* Lessor shall provide, install and replace all light bulbs, tubes, ballasts and starters. This stipulation also includes the parking area(s). All lighting shall be maintained as specified in **Attachment B**.
- d. *Heating, Ventilation and Air Conditioning.*
- i. All HVAC systems shall be designed, maintained and operated in a manner which maximizes energy efficiency. All equipment and systems shall be in operating order twenty-four (24) hours per day and shall be serviced and maintained by Lessor. Systems shall be inspected and serviced regularly to ensure proper balancing and calibration.
 - ii. Heating and air conditioning systems shall provide and maintain an inside automatically controlled temperature in accordance with **Attachment B**. Failure to follow **Attachment B** shall be considered a violation of the Lease.
 - iii. Lessor shall provide proof to Lessee of routine semi-annual maintenance/repairs to HVAC systems and respective components. Lessor shall provide the written reports to Lessee within thirty (30) days of completion of any service/repairs. The semi-annual maintenance will include, but is not limited to the service of the following items: boilers, boiler stacks, chillers, air handling units, coils, filters, belts, cooling towers, pumps, chilled water cooling systems, hot water heating systems, compressors, fan coil units, heat pumps, HVAC system controls, changing filters, checking baffles, ductwork, damper positions and system balance.
 - iv. All HVAC systems shall be tested and inspected by Lessor prior to Lessee occupancy to determine if the environmental conditions, as stated in the Lease, are met, and if adequate ventilation is provided for each area in accordance with the most current standards and guidelines of the American Society of Heating, Refrigerating & Air Conditioning Engineers ("ASHRAE"). Upon completion of testing and inspection, a certified report, signed by a registered engineer, who is certified by the National Environmental Balancing Bureau (NEBB), shall be submitted to the DGS/BRE, Room 503 North Office Building, Harrisburg, PA. 17125. The report shall be valid proof that the systems have been tested, adjusted, and balanced in accordance with the referenced standards, and be a true representation of how the systems are operating.

- v. Lessor shall be responsible throughout the term of the Lease to provide, at the request of Lessee, testing of the environmental conditions within the Premises, to include the submission of a detailed report signed by a registered engineer. The report should include recommendations for HVAC system modifications, if required to provide adequate ventilation and environmental conditions as stated per the Lease.
- vi. Lessor shall provide Lessee with a yearly preventative maintenance schedule for all HVAC systems.
- e. *Certification.* Lessor shall submit, within one (1) month after the Commencement Date, and for each year thereafter, current certifications for all service contractors referenced in this Paragraph, **Attachment B**, and **Attachment C** to prove that all service systems are being serviced and inspected on an acceptable periodic basis.
- f. *Building Manager.* Lessor shall have a building superintendent or a locally-designated representative available to proactively manage the Premises and to promptly respond to Lessee's requests to correct any deficiencies.
- g. *Painting.*
 - i. Lessor shall repaint the Premises every five (5) years during the term of this Lease, and any option terms, after Normal Business Hours. Lessor shall be responsible for the cost of moving furniture and equipment. Lessor shall contract with the furniture vendor selected by Lessee to move the furniture and equipment. Lessor shall notify Lessee at least forty-eight (48) hours in advance of repainting. Any repainting of the Premises, in whole or in part, may be waived by Lessee if it is determined that such repainting is not necessary.
 - ii. Lessor shall, upon Lessee's request, repaint portions of the Premises more frequently, if necessary, to maintain an appropriate appearance.
 - iii. Should the Premises contain lead-based paint, Lessor shall be responsible for the abatement of the lead-based paint in accordance with state and federal standards, whichever standards are higher or most stringent shall prevail.
- h. *Parking Lot.* Lessor shall be responsible, throughout the term of the Lease, for the maintenance and repair, including but not limited to, the black top of the Parking Lot. Lessor shall respond within ten (10) business days of notification by Lessee of holes and/or cracks, which pose a safety hazard, in the Parking Lot.

16. **Construction or Renovations.** Lessor shall:

- a. Construct and renovate the Premises, at Lessor's sole cost and expense, and in return for Rent paid by Lessee, in accordance with all plans and specifications set forth in **Attachment B** and **Attachment C**, and within the dates set forth in the Construction Completion Timeline Section of the Lease Cover Sheet; and
- b. Not begin any construction or renovation until after the Lease has been executed and a Pre-Construction Meeting has been held; and
- c. Comply with all applicable local, state and federal construction codes, regulations, statutes, ordinances and laws, applying whichever is most stringent. All work shall conform to the latest standards of the trade; and
- d. Furnish all labor, superintendence, materials, tools and equipment and perform all work necessary to complete all construction to the satisfaction of the Lessee; and
- e. Complete all general construction work in accordance with the Work as shown in **Attachment B** and **Attachment C**; and
- f. Not use any construction materials containing asbestos. If Lessor is renovating a space and finds friable materials containing asbestos, then Lessor shall remove the friable materials containing

asbestos in accordance with OSHA and EPA regulations. Contractors need to be trade specific licensed/certified to remove the friable materials containing asbestos; and

- g. Shall restore the area in such a manner that is acceptable to Lessee; and
- h. Shall comply with the Americans with Disabilities Act (ADA), whether or not specifically mentioned in the specifications or depicted on the drawings. All work must be in accordance with all local, state, and federal codes and regulations, whichever is most stringent, regarding ADA.

17. Completion.

- a. Upon receipt of an executed copy of this Lease, Lessor shall, all in accordance with the dates set forth in the Construction Completion Timeline Section of the Lease Cover Sheet, undertake the following:
 - i. Within thirty (30) days, furnish Lessee with detailed plans, specifications, drawings and other relevant construction documents (collectively, "Documents") pertaining to the construction and/or renovation;
 - ii. Within thirty (30) days after the receipt of the Documents, Lessee shall then review and either approve or reject the Documents. Lessor and Lessee agree that the approved Documents shall depict, as accurately as possible, the Premises. In the event Lessee's review exceeds thirty (30) days, the completion schedule shall be extended accordingly to incorporate the number of days exceeding the initial thirty (30) day review period;
 - iii. Within thirty (30) days of Lessee's approval of the Documents, Lessor shall then commence the construction and/or renovation in accordance with the approved Documents;
 - iv. Within thirty (30) days after Lessee has approved of the Documents, provide Lessee with a construction timeline;
 - v. Shall have the entire project completed, including final clean-up and the securing of all occupancy licenses or permits required by any governmental entity for occupancy, within One Hundred Eighty (180) days;
- b. Upon completion of the Work, to prove that the Premises are ready for occupancy, Lessor shall, at Lessor's expense:
 - i. Arrange for field measurements of the Premises and verification of the Net Usable Square Footage by a licensed architect and/or engineer;
 - ii. Provide Lessee with a written certificate from Lessor's architect/engineer that shall include a sealed set of drawings showing, in red, any changes in the dimension of the Premises, or in the Net Usable Square Feet, from the last set of drawings which Lessor provided to the DGS/BRE. The certificate shall: (i) include the date(s) when the measurements were done; (ii) specify the Net Usable Square Feet; and (iii) state that the Net Usable Square Feet were determined based upon the Commonwealth's net usable square footage definition. The certificate must be signed by the architect/engineer and bear such professional's seal. The Net Usable Square Feet shall be subject, at any time, to verification by Lessee;
 - iii. Furnish complete as-built drawings of the completed structure in an AutoCAD version and format acceptable to Lessee, together with hard copy drawn to a minimum 1/8 inch = 1 foot scale;
- c. Unless Lessee has agreed, in writing, to an extension of the completion date for the Work, if Lessor fails or refuses to comply with the provisions in this Paragraph, Lessee, after giving Lessor thirty (30) days' notice, in writing, shall have the right to terminate this Lease and/or exercise any other remedy it may have under the Lease or at law. Furthermore, in addition to these rights, Lessor must pay Lessee, at Lessee's option, as liquidated damages, one percent (1%) of the first year's annual Rent under this Lease for each and every day the Premises are not ready for occupancy by the date provided herein.

- d. No Rent shall be due or payable until:
 - i. Lessee completes and signs the Acceptance of Leased Premises and/or Renovations Inspection Report (GSRE-42-N (08-13) as set forth on **Exhibit 1** attached hereto; and
 - ii. Lessor has complied with all other provisions of this Lease.

18. **Certificate of Occupancy.**

- a. Lessor shall furnish and visibly display a copy of a Certificate of Occupancy, issued by any and all Federal, state, and local government entities, at the time of occupancy by Lessee of the Premises.
- b. If Lessee, after notifying Lessor prior to the action, increases or decreases staff, Lessor shall be responsible to make sure the Premises remains in compliance with all Federal, state, and local codes, regulations, and/or ordinances in relation to occupancy.

19. **Leasehold Improvements.**

- a. For any and all Leasehold Improvements completed by Lessor, at the request of Lessee, Lessor and Lessee agree and acknowledge that any Lease Amendment, or the Consent Form attached hereto and marked as **Exhibit 2**, must be executed and delivered to Lessor before any Leasehold Improvement is started.
- b. For any and all Leasehold Improvements completed by Lessee, Lessor and Lessee agree and acknowledge that a Consent Form must be executed and delivered to Lessor before any Leasehold Improvement is started.
- c. For any and all Leasehold Improvements requested by Lessee, Lessor and Lessee agree and acknowledge that:
 - i. Lessor shall obtain three (3) quotes from three (3) separate contractors/vendors for the Leasehold Improvement and submit all three (3) quotes to Lessee.
 - ii. A Consent Form or Lease Amendment must be executed and delivered to Lessor before any Leasehold Improvement is started.
- d. Any and all Leasehold Improvements shall be constructed in compliance with all applicable local, state and federal codes, regulations, statutes, and/or ordinances, applying whichever are most stringent.
- e. The Premises shall be restored in a manner that is acceptable to Lessee, when the Leasehold Improvement is completed by Lessor, or acceptable to Lessor, when the Leasehold Improvement is completed by Lessee.

20. **Fire/Safety.** Lessor shall:

- a. Provide, monitor, and maintain, at Lessor's expense, an NFPA compliant fire alarm and evacuation system that is in compliance with all Federal, state, and municipal laws, ordinances and regulations.
 - i. The fire alarm and evacuation system shall be audible and visual.
 - ii. The fire alarm and evacuation system shall be operational twenty-four (24) hours a day, seven (7) days a week.
 - iii. Lessor shall be responsible for providing, installing and maintaining a dedicated voice analog/digital telephone line for the fire and security systems.
 - iv. Lessor shall have the fire alarm and evacuation system serviced and tested annually, in compliance with **Attachment B**; and Lessor shall furnish proof of same to Lessee upon request. All testing of the fire alarm and evacuation system shall occur after Normal Business Hours.

- v. Lessor shall provide Lessee a yearly maintenance schedule for the fire alarm and evacuation system.
- vi. Lessor shall provide ongoing training of the fire alarm and evacuation system, as requested by Lessee, during the term of the Lease.
- b. Provide, monitor, and maintain, at Lessor's expense, an NFPA compliant fire suppression system, including but not limited to fire extinguishers and sprinklers, in compliance with all Federal, state, and municipal laws, ordinances and regulations.
 - i. Lessor shall have the fire suppression system serviced and tested annually, in compliance with **Attachment B**, and furnish proof of same to Lessee upon request. All testing of the fire suppression system shall occur after Normal Business Hours.
 - ii. Lessor shall provide Lessee a yearly maintenance schedule for the fire suppression system.
 - iii. Lessor shall provide ongoing training, as requested by Lessee, during the term of the Lease, of the fire suppression system.
 - iv. Lessor shall be responsible for the inspection and recharging of all fire extinguishers.
- c. Coordinate with the Using Agency a bi-annual Emergency Evacuation Drill.
- d. Prior to any installation and/or updates to either the fire alarm and evacuation system or the fire suppression system or the security system, obtain Lessee's approval of the installation and/or update.
- e. Upon request from Lessee, provide a new locking system and/or associated hardware, after a break-in or a series of thefts or other similar unusual occurrences at the Premises.
- f. Annually test and inspect, without an additional charge to Lessee, any and all other safety systems, including but not limited to emergency generators, on the Premises to ensure proper operation. All testing and inspections shall be done in compliance with all applicable Federal, state, and municipal laws, ordinances and regulations.
- g. Shall display any and all inspection certificates as appropriate and shall provide any and all inspection certificates to Lessee upon Lessee's request.

21. **Insurance.**

- a. At all times during the term of the Lease, Lessor shall procure and maintain, at its expense, the following types of insurance, issued by companies acceptable to Lessee and authorized to conduct such business under the laws of the Commonwealth of Pennsylvania:
 - i. Worker's Compensation Insurance for all of Lessor's employees and those of any contractor engaged in work at the Premises, in accordance with the Worker's Compensation Act of 1915 and any supplements or amendments thereto.
 - ii. Public Liability Insurance to protect Lessee, Lessor and any and all contractors from claims for damages for personal injury (including bodily injury), sickness or disease, accidental death and damage to property, including loss of use resulting from property damage, which may arise from services performed by Lessor, its agents or employees under this Lease, or from an alleged defective, dangerous or untenable condition of the Premises. The limits of such insurance shall be in an amount not less than \$500,000 each person and \$2,000,000 each occurrence. Such policy shall name the Commonwealth of Pennsylvania as an additional insured.
 - iii. Builders Risk. During the period of any construction of the Premises or the building (including, without limitation, the Work), Lessor shall purchase and maintain (or shall cause its general contractor to purchase and maintain) Builders Risk "All Risk" or equivalent policy form in the amount of the initial construction contract sum plus the value of subsequent contract modifications and the cost of materials supplied or installed by others, comprising the total value of the entire Building on a replacement cost basis without optional deductibles. Such

property insurance shall also cover portions of the Work stored off the site and portions of the Work in transit. Such insurance shall, unless otherwise agreed in writing by all persons and entities that are beneficiaries of such insurance, (a) be maintained until the construction project is complete, (b) include at least the interests of Lessor, Lessee, and any and all contractors, and (c) include Loss of Use insurance due to a covered loss, including Leasehold Interest Coverage in favor of Lessee subject to a minimum limit of twice the Rent due for the first Lease Year. The period of coverage for this Loss of Use shall be, at a minimum, the length of the original construction period of the applicable construction project.

- iv. Property. At all other periods during the term of the Lease, Lessor shall provide "All-Risk" or equivalent property insurance covering the Building and appurtenant structures and improvements up to the full replacement cost thereof, including all fixtures, equipment, machinery and apparatus which constitute a permanent part of such Building, and other structures and improvements. If the coverage is available and commercially appropriate (with commercially appropriate sublimits), such property insurance shall insure against all risks of direct physical loss or damage including without limitation the perils of fire (with extended coverage), and physical loss or damage including theft, vandalism, malicious mischief, collapse, earthquake, flood, windstorm, and boiler/machinery. Such policy shall also include coverage for debris removal and the enforcement of any legal requirements requiring the upgrading, demolition, reconstruction or replacement of any portion of the Premises as the result of a covered loss. Such policy shall permit partial occupancy as construction progresses.
- b. At all times when Lessor is obligated to maintain insurance coverage as provided in this Paragraph, Lessor shall comply with the following requirements:
- i. All policies will be issued by carriers having ratings of Best's Insurance Guide A- or better, or its substantial equivalent if such Guide is no longer published, and admitted or permitted to engage in the business of insurance in the Commonwealth of Pennsylvania for the past five years. If any coverage is provided by an unrated captive, such captive will have financial resources of equivalent standing to those meriting a rating of Best's Insurance Guide A- or better, with audited financials of the captive to be furnished annually to Lessee.
 - ii. Any non-standard policy or endorsement other than as specified herein must be approved in advance in writing by Lessee, which approval shall not be unreasonably withheld, conditioned or delayed. No policy will contain a deductible or self-insured retention in excess of the limits set forth above, unless mutually agreed by Lessor and Lessee in their sole discretion.
 - iii. If the forms of policies, endorsements, certificates, or evidence of insurance required hereunder are superseded or discontinued, Lessee will have the right to require Lessor to provide other substantially equivalent forms consistent with the standards observed by prudent and reputable owners of office buildings of the same class as the Building, in the locality of the Building. Evidence of the insurance coverage required to be maintained by Lessor hereunder, represented by certificates of insurance issued by the insurance carrier(s) and constituting actual evidence of coverage, must be furnished to Lessee, at the address set forth in Paragraph 36 "Notice," at least thirty (30) days prior to the Commencement Date, and at least thirty (30) days prior to the expiration of current policies. Such certificates will specify the additional insured status (as applicable) of the Commonwealth of Pennsylvania. Such certificates will state that persons and parties required to be named hereunder as additional insureds have been so named, and that such additional insureds will be notified in writing thirty (30) days prior to cancellation, material change, or non-renewal of insurance. The "endeavor to" language contained in any cancellation notice section of such certificate shall be deleted. Such certificates, or a separate writing issued by the insurer or its agent together with such certificate, shall set forth the amounts of deductibles and all self-insured retentions.
 - iv. If Lessor fails to comply with its covenants made in this Paragraph, Lessee may, at its option, cause insurance as aforesaid to be issued, and in such event Lessor agrees to pay the premium for such insurance promptly upon Lessee's demand.
 - v. Lessor may carry any insurance required by this Paragraph under a blanket policy, applicable to the property to be insured hereunder for the risks and in the amounts required pursuant to

this Paragraph, provided that all requirements of this Paragraph shall be complied with in respect of such policy.

vi. If requested in writing, Lessor shall provide to Lessee a certified copy of any and all insurance policies or endorsements required by this Lease, and Lessor shall provide such certified policies to Lessee within thirty (30) days after written request is made. These certificates shall contain a provision that the coverage afforded under the policies will not be canceled or changed until at least thirty (30) days' written notice has been given to Lessee.

i. All liability insurance to be maintained by Lessor shall be on an occurrence basis.

c. At least thirty (30) days prior to the Commencement Date, Lessor shall provide Lessee with evidence, reasonably satisfactory to Lessee, that Lessor requires any other tenants of the Building to carry commercial reasonable limits of liability insurance to respond to liability exposures associated with such other tenants' occupancy of the Building.

22. **Hold Harmless.** Lessor shall save and hold harmless Lessee, and its officers, agents and employees, or any of them, from any and all claims, demands, actions, damages, losses liability, and expense (including, but not limited to, consequential damages and reasonable attorney's fees) of any nature based upon or arising out of:

a. Any service performed by Lessor, its agents or employees under this Lease, except such services as are properly performed at the express direction of Lessee; or

b. Any actual or alleged defective, dangerous or untenable condition of the Premises; or

c. Violations of, or noncompliance of the Premises, any statute, ordinance, rule or regulation of any governmental authority, or violations of, or noncompliance with, any statute, ordinance, rule or regulation of any governmental authority on the part of Lessor, its employees, agents or contractors; or

d. Any breach of any of the covenants, representations or warranties of Lessor contained in this Lease; or

e. Any personal injury, death or damage to property caused by Lessor, its employees, agents or contractors.

23. **Damage/Destruction.** In the event of damage to the Premises by fire, flood, lightning, or other Act of God, or act of terrorism rendering it impossible or substantially inconvenient for Lessee to continue to occupy or use the Premises for its operations, the Lessor, after notice from the Lessee of the condition shall have sixty (60) days to repair and/or restore the Premises to a tenantable condition. If Lessor fails to repair and/or restore the Premises within said period of sixty (60) days, or if Lessor fails to make reasonable progress during the sixty (60) day period, as determined by Lessee in its sole discretion, Lessee may, at its option: a.) terminate this Lease by giving Lessor thirty (30) days' written termination notice or b.) after first giving Lessor fifteen (15) days' written notice, repair and restore the Premises to a tenantable condition, and deduct such costs made in restoration of the Premises from the Rent due the Lessor. At Lessee's option, payment of Rent shall abate as long as the Premises remains in an untenable condition after notice to Lessor and shall resume only after the condition has been substantially corrected. Such abatement shall be prorated on the portion of the Premises that is or remains untenable.

24. **Encumbrances.** Lessor covenants:

a. That it has good and clear title to the Premises, or that it has the right and authority from the owner of the Premises, to lease the Premises to Lessee.

b. That Lessee shall enjoy peaceful and uninterrupted possession of the Premises during the term of this Lease.

c. That Lessor shall execute and provide to Lessee and any mortgagee which may hold an encumbrance against the Premises, a reasonable Subordination, Non-Disturbance and Attornment Agreement with respect to matters related to this Lease and/or the status of performance of obligations by the parties under this Lease.

25. Regulations.

- a. With full understanding by Lessor of the intended use of the Premises by Lessee, Lessor shall ensure that the Premises conform to all applicable laws, codes, ordinances, rules and regulations (collectively, "Regulatory Requirements").
- b. Lessor, at its sole expense, shall promptly take action to comply with changes in any Regulatory Requirements when such changes occur during the term of this Lease and any renewal thereof.
- c. Lessor shall be responsible for the payment of any signage fees imposed by local governmental authorities.

26. Communication Lines.

- a. Subject to all applicable governmental requirements and restrictions, Lessee shall have a non-exclusive right to install, maintain, upgrade, operate, repair and replace, at Lessee's cost, on the roof of the Premises "Rooftop Communication Devices" or "RCD".
 - i. RCD may include, without limitation, a back-up generator, and transmitter(s), microwave or satellite dishes or antenna(s), or other communications fixtures or equipment utilized for receiving or transmitting voice, video, data or other communications, together with all wiring, equipment and facilities reasonably necessary to make the same functional and connected with the Premises.
 - ii. The RCDs shall be for the sole use of Lessee in the operation of their business within and outside the Premises (including, without limitation, public broadcast services), but not for any sublicense for profit.
- b. Subject to all applicable governmental requirements and restrictions, Lessee shall have a non-exclusive right to interconnect the RCD with Lessee's other equipment located in the Premises using risers, conduits, chases, and other mutually agreeable locations in the Premises.
- c. If the Lessee desires to install voice, data or other communications lines (including, without limitation, fiber optic lines) to the Premises, or to communications equipment devices serving the Premises but located outside of the Premises, Lessor shall approve, which approval shall not be unreasonably withheld, delayed or conditioned.
 - i. The allocation of space in risers and conduits not installed by Lessee;
 - ii. The installation of risers and conduits by Lessee;
 - iii. The use of mechanical or equipment space, and appropriate shielding.
- d. In the event of any conflict between any use or installation made, or proposed to be made, by Lessee with any other occupants, tenants, or users of Lessor's building, if such conditions should exist, Lessor shall use its good faith best efforts to afford Lessee priority in such use or installation of communication lines, consistent with Lessor's existing obligations to other occupants, tenants or users of Lessor's building and Lessor's operation of their building.
- e. Lessor shall cooperate with Lessee in establishing protocols enabling Lessee and Lessee's contractors to obtain immediate access to communications rooms within the Premises and/or Lessor's building which contain Lessee's communications equipment.

27. Vending.

- a. Lessee reserves the right to install and operate vending machines on the Premises without any additional payment to Lessor or any sharing of the income derived from the operation of the vending machines.
- b. Lessor shall not install or operate any vending machines in the Premises unless agreed upon by the Using Agency.

- c. If the Premises are located in a multi-tenant building, Lessor may install vending machines in the Common Areas of the Building.
- d. All receipts from the operation of vending machines, after costs of goods sold, and all commissions paid by a commercial vending concern, shall accrue to the licensed blind vendor operating the vending machines on the Premises or, if none, to the Commonwealth Employment Fund for the Blind, as required by the "*Little Randolph-Sheppard Act*", 71 PS §§ 580.1-20.

28. Asbestos.

- a. Lessor represents and warrants that the Premises and/or Lessor's building and/or any of Lessor's building systems or components serving the Premises, and all Common Areas of the Premises will, no later than the Commencement Date, be free of any and all asbestos and asbestos containing materials not properly encapsulated or enclosed in compliance with all applicable law and governmental requirements, without cost or expense to Lessee.
- b. Lessor shall complete and sign the Asbestos Certification attached hereto and marked as **Exhibit 3**, and agrees to comply with the conditions and requirements within the Asbestos Certification.
- c. Lessor agrees to protect, indemnify and save harmless Lessee from and against any and all liabilities, losses, damages, costs, expenses (including, without limitation, reasonable attorney's fees and costs), cause of action, suits, claims, demands or judgments of any nature arising from any injuries to, or the death of any person growing out of, or connected with, the presence of asbestos in the Premises or the Building or any of the Building systems or components serving the Premises.

29. Assignment by Lessor.

- a. Lessee shall not be obligated to recognize any assignment or other transfer of the Lease by Lessor, nor shall Lessee be obligated to pay the Rent or other sums payable to Lessor hereunder, to any assignee or other transferee of the interest of Lessor in the Lease, unless and until such assignment or transfer has been approved, in writing, by Lessee, which approval shall not be unreasonably withheld.
- b. Until such approval is granted, Lessee shall have the right to continue to recognize and treat the assigning Lessor as the "Lessor" for all purposes of the Lease.
- c. Lessor shall provide a written request for approval of assignment or other transfer of the Lease by Lessor to Lessee at least ninety (90) days prior to transfer.
- d. Within thirty (30) days following receipt of Lessor's written notice, Lessee shall advise Lessor in writing of the applications, documents and other information required to enable Lessee to assess and act upon Lessor's request for approval.
- e. Within sixty (60) days following receipt by Lessee of all completed applications, documents and other information required to enable Lessee to assess and act upon Lessor's request for approval, Lessee shall provide written notice of their approval or disapproval of such assignment or other transfer.
- f. In no event, shall Lessee's failure to provide such written notice within the sixty (60) days be deemed to constitute Lessee's approval of such assignment or other transfer.

30. Assignment and Subletting by Lessee.

- a. Lessee shall have the right to assign the Lease or sublet all or any part of the Premises subject to the approval of Lessor, which approval shall not be unreasonably withheld, delayed or conditioned.
- b. Notwithstanding the foregoing, and without requiring Lessor's approval, Lessee shall be permitted to assign the Lease or sublet all or any portions of the Premises to any departments or agencies of the Commonwealth of Pennsylvania.
- c. Lessee will not be released from liability as a result of any assignment or sublease.

- d. Notwithstanding the foregoing, use of the Premises by another Commonwealth agency shall not be deemed a sublease or assignment and shall not require the consent or approval of Lessor.

31. Right to Know Law Requirements.

- a. The *Pennsylvania Right-to-Know Law, 65 P.S. §§ 67.101-3104* ("RTKL") applies to this Lease.
- b. If Lessee needs Lessor's assistance in any matter arising out of the RTKL related to this Lease, it shall notify Lessor using the legal contact information provided in this Lease. Lessor, at any time, may designate a different contact for such purpose upon reasonable prior written notice to Lessee.
- c. Upon written notification from Lessee that it requires Lessor's assistance in responding to a request under the RTKL for information in Lessor's possession, constituting, or alleged to constitute, a public record in accordance with the RTKL ("Requested Information"), Lessor shall:
 - i. Provide Lessee, within ten (10) calendar days after receipt of written notification, access to, and copies of, any document or information in Lessor's possession arising out of this Lease that Lessee reasonably believes is Requested Information and may be a public record under the RTKL; and
 - ii. Provide such other assistance as Lessee may reasonably request, in order to comply with the RTKL with respect to this Lease.
- d. If Lessor considers the Requested Information to include a request for a Trade Secret or Confidential Proprietary Information, as those terms are defined by the RTKL, or other information that the Lessor considers exempt from production under the RTKL, Lessor must notify Lessee and provide, within seven (7) calendar days of receiving the written notification, a written statement signed by a representative of Lessor, explaining why the requested material is exempt from public disclosure under the RTKL.
- e. Lessee will rely upon the written statement from Lessor in denying a RTKL request for the Requested Information unless Lessee determines that the Requested Information is clearly not protected from disclosure under the RTKL. Should Lessee determine that the Requested Information is clearly not exempt from disclosure, Lessor shall provide the Requested Information within five (5) business days of receipt of written notification of Lessee's determination.
- f. If Lessor fails to provide the Requested Information within the time period required by these provisions, Lessor shall indemnify and hold Lessee harmless from any damages, penalties, costs, detriment or harm that Lessee may incur as a result of Lessor's failure, including any statutory damages assessed against Lessee.
- g. Lessee will reimburse Lessor for any costs associated with complying with these provisions only to the extent allowed under the fee schedule established by the Office of Open Records or as otherwise provided by the RTKL if the fee schedule is inapplicable.
- h. Lessor may file a legal challenge to any Lessee decision to release a record to the public with the Office of Open Records, or in the Pennsylvania courts; however, Lessor shall indemnify Lessee for any legal expenses incurred by Lessee as a result of such a challenge and shall hold Lessee harmless from any damages, penalties, costs, detriment or harm that Lessee may incur as a result of Lessor's failure, including any statutory damages assessed against Lessee, regardless of the outcome of such legal challenge. As between the parties, Lessor agrees to waive all rights or remedies that may be available to it as a result of Lessee's disclosure of Requested Information pursuant to the RTKL.
- i. Lessor's duties relating to the RTKL are continuing duties that survive the expiration of this Lease and shall continue as long as Lessor has Requested Information in its possession.

32. Payment of Prevailing Minimum Wages. Lessor and Lessor's contractor(s) must comply with the following conditions, provisions and requirements in the construction of the building, substantial rehabilitation of the building and/or substantial alterations to the Premises:

- a. Lessor and Lessor's contractors shall pay at least the wage rates as determined by the Secretary of the Pennsylvania Department of Labor and Industry and shall comply with the conditions of the *Prevailing Wage Act of August 15, 1961, 43 P.S. § 165-1 et seq.*, and the regulations issued thereto, to assure the full and proper payment of the rates.
- b. Workers in the construction of the building, substantial rehabilitation of the building and/or substantial alterations to the Premises shall be paid at least the general prevailing minimum wage rates as set forth in the prevailing minimum wage predetermination, issued by the Secretary of Labor and Industry, attached hereto and marked as **Exhibit 4**.
- c. These requirements apply to work performed in the construction of the building, substantial rehabilitation of the building and/or substantial alterations to the Premises by Lessor, Lessor's contractor(s) and all subcontractors.
- d. Lessor shall insert in all its contracts for the construction of the building, substantial rehabilitation of the building and/or substantial alterations to the Premises and shall require the contractor(s) to insert in each of its subcontracts the stipulations contained in these provisions.
- e. No workers may be employed in the construction of the building, substantial rehabilitation of the building and/or substantial alterations to the Premises except in accordance with the classifications in the prevailing minimum wage predetermination of the Secretary. If additional or different classifications are necessary, Lessor shall request the Department of General Services to petition the Secretary of Labor and Industry for rates for additional or different classifications.
- f. Workers employed or working in the construction of the building, substantial rehabilitation of the building and/or substantial alterations to the Premises shall be paid unconditionally, regardless of whether a contractual relationship exists or the nature of a contractual relationship which may be alleged to exist between a contractor, subcontractor and worker, at least once a week, without deduction or rebate, on any account, either directly or indirectly except authorized deductions, the full amounts due at the time of payment, computed at the rates applicable to the time worked in the appropriate classification. Nothing in the lease, the *Prevailing Wage Act* or the regulations promulgated pursuant to the Act prohibits the payment of more than the general prevailing minimum wage rates as determined by the Secretary to a worker on a public work.
- g. Lessor shall require its contractor(s) and each subcontractor to post for the entire period of the construction of the building, substantial rehabilitation of the building and/or substantial alterations to the Premises the wage determination decisions of the Secretary, including the effective date of changes thereof, in a prominent and easily accessible place or places at the site of the work and at the places used by them to pay workers their wages. The posted notice of wage rates shall contain the following information:
 - i. The name of project.
 - ii. The name of the Commonwealth agency that will be the tenant in the facility.
 - iii. The crafts and classifications of workers listed in the Secretary's general prevailing minimum wage rate determination for the particular project.
 - iv. The general prevailing minimum wage rates determined for each craft and classification and the effective date of changes.
 - v. A statement advising workers that if they have been paid less than the general prevailing minimum wage rate for their job classification or that the contractor or subcontractor are not complying with the act or this title, they may file a protest in writing with the Secretary of Labor and Industry within 3 months of the date of the occurrence, objecting to the payment to a contractor to the extent of the amount due or to become due to them as wages for work performed on the public work project. A worker paid less than the rate specified in the contract shall have a civil right to action for the difference between the wage paid and the wages stipulated in the contract, which right of action shall be exercised within 6 months from the occurrence of the event creating the right.

- h. Lessor shall require its contractor(s) and each subcontractor to keep an accurate record showing the name, craft or classification, number of hours worked per day and the actual hourly rate of wage paid, including employee benefits, to each worker employed by him in connection with the public work. The record shall include deductions from each worker. The record shall be preserved for 2 years from the date of payment and shall be open at reasonable hours to the inspection of the Department of General Services and the Department of Labor and Industry.
- i. Apprentices shall be limited to numbers in accordance with a bona fide apprenticeship program registered with and approved by The Pennsylvania Apprenticeship and Training Council and only apprentices whose training and employment are in full compliance with *The Apprenticeship and Training Act (43 P.S. §§ 90.1-90.10), approved July 14, 1961*, and the regulations issued thereto shall be employed on the public work project. A worker using the tools of a craft who does not qualify as an apprentice within this Paragraph shall be paid the rate predetermined for journeymen in that particular craft or classification.
- j. Wages shall be paid without deductions except authorized deductions. Employers not parties to a contract requiring contributions for employee benefits which the Secretary of Labor and Industry has determined to be included in the general prevailing minimum wage rate shall pay the monetary equivalent thereof directly to the workers.
- k. Payment of compensation to workers for work performed on public work on a lump sum basis, or a piece work system, or a price certain for the completion of a certain amount of work, or the production of a certain result shall be deemed a violation of the *Prevailing Wage Act* and the Lease, regardless of the average hourly earnings resulting therefrom.
- l. Lessor shall require its contractor(s) and each subcontractor to file a statement each week and a final statement at the conclusion of the work on the contract under oath, and in form satisfactory to the Secretary, certifying that workers have been paid wages in strict conformity with the provisions of the contract as prescribed by this provision or if wages remain unpaid to set forth the amount of wages due and owing to each worker respectively.
- m. The provisions of the *Prevailing Wage Act (43 P.S. §§ 165-1 through 165-17)* and the regulations issued thereto (*34 Pa. Code §§ 9.101 through 9.112*) are incorporated by reference in the Lease.
- n. As used in this Paragraph, "substantial rehabilitation" is the conversion or adaptation of an existing facility into a safe, structurally sound building, by gutting and extensive re-construction, to make the building suitable for use by Lessee.
- o. As used in this Paragraph, "substantial alterations" are those alterations to an existing facility by Lessor in accordance with the specifications, plans, or drawings contained in the Lease or where the final plans, drawings or specifications must be reviewed and approved by Lessee.

33. Accessibility to the Premises by Individuals With Disabilities. For the purpose of these provisions, the term contractor is defined as any person, including, but not limited to, a bidder, offeror, supplier, or grantee, who will furnish or perform or seeks to furnish or perform, goods, supplies, services, construction or other activity, under a purchase order, contract, or grant with the Commonwealth.

During the term of this agreement, the contractor agrees as follows:

1. Pursuant to federal regulations promulgated under the authority of the *Americans with Disabilities Act, 28 C. F. R. § 35.101 et seq.*, the contractor understands and agrees that no individual with a disability shall, on the basis of the disability, be excluded from participation in this agreement or from activities provided for under this agreement. As a condition of accepting and executing this agreement, the contractor agrees to comply with the "*General Prohibitions Against Discrimination*," 28 C. F. R. § 35.130, and all other regulations promulgated under *Title II of the Americans with Disabilities Act* which are applicable to the benefits, services, programs, and activities provided by the Commonwealth through contracts with outside contractors.
2. The contractor shall be responsible for and agrees to indemnify and hold harmless the Commonwealth from all losses, damages, expenses, claims, demands, suits, and actions brought by any party against the Commonwealth as a result of the contractor's failure to comply with the provisions of this Paragraph.

34. **Contractor Integrity Provisions.** The word “contractor” as used herein shall refer to Lessor. It is essential that those who seek to contract with the Commonwealth observe high standards of honesty and integrity. They must conduct themselves in a manner that fosters public confidence in the integrity of the Commonwealth procurement process.

In furtherance of this policy, Contractor agrees to the following:

- a. Contractor shall maintain the highest standards of honesty and integrity during the performance of this contract and shall take no action in violation of state or federal laws or regulations or any other applicable laws or regulations, or other requirements applicable to Contractor or that govern contracting with the Commonwealth.
- b. Contractor shall establish and implement a written business integrity policy, which includes, at a minimum, the requirements of these provisions as they relate to Contractor employee activity with the Commonwealth and Commonwealth employees, and which is distributed and made known to all Contractor employees.
- c. Contractor, its affiliates, agents and employees shall not influence, or attempt to influence, any Commonwealth employee to breach the standards of ethical conduct for Commonwealth employees set forth in the *Public Official and Employees Ethics Act, 65 Pa.C.S. §§1101 et seq.*; the *State Adverse Interest Act, 71 P.S. §776.1 et seq.*; and the *Governor’s Code of Conduct, Executive Order 1980-18, 4 Pa. Code §7.151 et seq.*, or to breach any other state or federal law or regulation.
- d. Contractor, its affiliates, agents and employees shall not offer, give, or agree or promise to give any gratuity to a Commonwealth official or employee or to any other person at the direction or request of any Commonwealth official or employee.
- e. Contractor, its affiliates, agents and employees shall not offer, give, or agree or promise to give any gratuity to a Commonwealth official or employee or to any other person, the acceptance of which would violate the *Governor’s Code of Conduct, Executive Order 1980-18, 4 Pa. Code §7.151 et seq.* or any statute, regulation, statement of policy, management directive or any other published standard of the Commonwealth.
- f. Contractor, its affiliates, agents and employees shall not, directly or indirectly, offer, confer, or agree to confer any pecuniary benefit on anyone as consideration for the decision, opinion, recommendation, vote, other exercise of discretion, or violation of a known legal duty by any Commonwealth official or employee.
- g. Contractor, its affiliates, agents, employees, or anyone in privity with him or her shall not accept or agree to accept from any person, any gratuity in connection with the performance of work under the contract, except as provided in the contract.
- h. Contractor shall not have a financial interest in any other contractor, subcontractor, or supplier providing services, labor, or material on this project, unless the financial interest is disclosed to the Commonwealth in writing and the Commonwealth consents to Contractor’s financial interest prior to Commonwealth execution of the contract. Contractor shall disclose the financial interest to the Commonwealth at the time of bid or proposal submission, or if no bids or proposals are solicited, no later than Contractor’s submission of the contract signed by Contractor.
- i. Contractor, its affiliates, agents and employees shall not disclose to others any information, documents, reports, data, or records provided to, or prepared by, Contractor under this contract without the prior written approval of the Commonwealth, except as required by the *Pennsylvania Right-to-Know Law, 65 P.S. §§ 67.101-3104*, or other applicable law or as otherwise provided in this contract. Any information, documents, reports, data, or records secured by Contractor from the Commonwealth or a third party in connection with the performance of this contract shall be kept confidential unless disclosure of such information is:
 - i. Approved in writing by the Commonwealth prior to its disclosure; or
 - ii. Directed by a court or other tribunal of competent jurisdiction unless the contract requires prior Commonwealth approval; or

- iii. Required for compliance with federal or state securities laws or the requirements of national securities exchanges; or
 - iv. Necessary for purposes of Contractor's internal assessment and review; or
 - v. Deemed necessary by Contractor in any action to enforce the provisions of this contract or to defend or prosecute claims by or against parties other than the Commonwealth; or
 - vi. Permitted by the valid authorization of a third party to whom the information, documents, reports, data, or records pertain: or
 - vii. Otherwise required by law.
- j. Contractor certifies that neither it nor any of its officers, directors, associates, partners, limited partners or individual owners has not been officially notified of, charged with, or convicted of any of the following and agrees to immediately notify the Commonwealth agency contracting officer in writing if and when it or any officer, director, associate, partner, limited partner or individual owner has been officially notified of, charged with, convicted of, or officially notified of a governmental determination of any of the following:
- i. Commission of embezzlement, theft, forgery, bribery, falsification or destruction of records, making false statements or receiving stolen property.
 - ii. Commission of fraud or a criminal offense or other improper conduct or knowledge of, approval of or acquiescence in such activities by Contractor or any affiliate, officer, director, associate, partner, limited partner, individual owner, or employee or other individual or entity associated with:
 - (i) obtaining;
 - (ii) attempting to obtain; or
 - (iii) performing a public contract or subcontract.

Contractor's acceptance of the benefits derived from the conduct shall be deemed evidence of such knowledge, approval or acquiescence.

- iii. Violation of federal or state antitrust statutes.
- iv. Violation of any federal or state law regulating campaign contributions.
- v. Violation of any federal or state environmental law.
- vi. Violation of any federal or state law regulating hours of labor, minimum wage standards or prevailing wage standards; discrimination in wages; or child labor violations.
- vii. Violation of the *Act of June 2, 1915 (P.L. 736, No. 338)*, known as the *Workers' Compensation Act, 77 P.S. 1 et seq.*
- viii. Violation of any federal or state law prohibiting discrimination in employment.
- ix. Debarment by any agency or department of the federal government or by any other state.
- x. Any other crime involving moral turpitude or business honesty or integrity.

Contractor acknowledges that the Commonwealth may, in its sole discretion, terminate the contract for cause upon such notification or when the Commonwealth otherwise learns that Contractor has been officially notified, charged, or convicted.

- k. If this contract was awarded to Contractor on a non-bid basis, Contractor must, (as required by *Section 1641 of the Pennsylvania Election Code*) file a report of political contributions with the Secretary of the Commonwealth on or before February 15 of the next calendar year. The report must include an itemized list of all political contributions known to Contractor by virtue of the knowledge

possessed by every officer, director, associate, partner, limited partner, or individual owner that has been made by:

- i. Any officer, director, associate, partner, limited partner, individual owner or members of the immediate family when the contributions exceed an aggregate of one thousand dollars (\$1,000) by any individual during the preceding year; or
- ii. Any employee or members of his immediate family whose political contribution exceeded one thousand dollars (\$1,000) during the preceding year.

To obtain a copy of the reporting form, Contractor shall contact the Bureau of Commissions, Elections and Legislation, Division of Campaign Finance and Lobbying Disclosure, Room 210, North Office Building, Harrisburg, PA 17120.

- l. Contractor shall comply with requirements of the *Lobbying Disclosure Act, 65 Pa.C.S. § 13A01 et seq.*, and the regulations promulgated pursuant to that law. Contractor employee activities prior to or outside of formal Commonwealth procurement communication protocol are considered lobbying and subjects the Contractor employees to the registration and reporting requirements of the law. Actions by outside lobbyists on Contractor's behalf, no matter the procurement stage, are not exempt and must be reported.
- m. When Contractor has reason to believe that any breach of ethical standards as set forth in law, the Governor's Code of Conduct, or in these provisions has occurred or may occur, including but not limited to contact by a Commonwealth officer or employee which, if acted upon, would violate such ethical standards, Contractor shall immediately notify the Commonwealth contracting officer or Commonwealth Inspector General in writing.
- n. Contractor, by submission of its bid or proposal and/or execution of this contract and by the submission of any bills, invoices or requests for payment pursuant to the contract, certifies and represents that it has not violated any of these contractor integrity provisions in connection with the submission of the bid or proposal, during any contract negotiations or during the term of the contract.
- o. Contractor shall cooperate with the Office of Inspector General in its investigation of any alleged Commonwealth employee breach of ethical standards and any alleged Contractor non-compliance with these provisions. Contractor agrees to make identified Contractor employees available for interviews at reasonable times and places. Contractor, upon the inquiry or request of the Office of Inspector General, shall provide, or if appropriate, make promptly available for inspection or copying, any information of any type or form deemed relevant by the Inspector General to Contractor's integrity and compliance with these provisions. Such information may include, but shall not be limited to, Contractor's business or financial records, documents or files of any type or form that refers to or concern this contract.
- p. For violation of any of these Contractor Integrity Provisions, the Commonwealth may terminate this and any other contract with Contractor, claim liquidated damages in an amount equal to the value of anything received in breach of these provisions, claim damages for all additional costs and expenses incurred in obtaining another contractor to complete performance under this contract, and debar and suspend Contractor from doing business with the Commonwealth. These rights and remedies are cumulative, and the use or non-use of any one shall not preclude the use of all or any other. These rights and remedies are in addition to those the Commonwealth may have under law, statute, regulation, or otherwise.
- q. For purposes of these Contractor Integrity Provisions, the following terms shall have the meanings found in this Paragraph.
 - i. "Confidential information" means information that a) is not already in the public domain; b) is not available to the public upon request; c) is not or does not become generally known to Contractor from a third party without an obligation to maintain its confidentiality; d) has not become generally known to the public through an act or omission of Contractor; or e) has not been independently developed by Contractor without the use of confidential information of the Commonwealth.

- ii. "Consent" means written permission signed by a duly authorized officer or employee of the Commonwealth, provided that where the material facts have been disclosed, in writing, by pre-qualification, bid, proposal, or contractual terms, the Commonwealth shall be deemed to have consented by virtue of execution of this contract.
- iii. "Contractor" means the individual or entity that has entered into this contract with the Commonwealth, including those directors, officers, partners, managers, and owners having more than a five percent interest in Contractor.
- iv. "Financial interest" means:
 - (i) Ownership of more than a five percent interest in any business; or
 - (ii) Holding a position as an officer, director, trustee, partner, employee, or holding any position of management.
- xi. "Gratuity" means tendering, giving or providing anything of more than nominal monetary value including, but not limited to, cash, travel, entertainment, gifts, meals, lodging, loans, subscriptions, advances, deposits of money, services, employment, or contracts of any kind. The exceptions set forth in the *Governor's Code of Conduct, Executive Order 1980-18*, the *4 Pa. Code §7.153(b)*, shall apply.
- xii. "Immediate family" means a spouse and any unemancipated child.
- xiii. "Non-bid basis" means a contract awarded or executed by the Commonwealth with Contractor without seeking bids or proposals from any other potential bidder or offeror.
- xiv. "Political contribution" means any payment, gift, subscription, assessment, contract, payment for services, dues, loan, forbearance, advance or deposit of money or any valuable thing, to a candidate for public office or to a political committee, including but not limited to a political action committee, made for the purpose of influencing any election in the Commonwealth of Pennsylvania or for paying debts incurred by or for a candidate or committee before or after any election.

34. **Contractor Responsibility Provisions.** For the purpose of these provisions, the term contractor is defined as any person, including, but not limited to, a bidder, offeror, loan recipient, grantee or lessor, who has furnished or performed or seeks to furnish or perform, goods, supplies, services, leased space, construction or other activity, under a contract, grant, lease, purchase order or reimbursement agreement with the Commonwealth. The term contractor includes a permittee, licensee, or any agency, political subdivision, instrumentality, public authority, or other public entity in the Commonwealth. It shall be understood that the word "Contractor" as used herein shall refer to Lessor.

- a. The Contractor certifies, in writing, for itself and its subcontractors required to be disclosed or approved by the Commonwealth, that as of the date of its execution of this Bid/Contract, that neither the Contractor, nor any such subcontractors, are under suspension or debarment by the Commonwealth or any governmental entity, instrumentality, or authority and, if the Contractor cannot so certify, then it agrees to submit, along with the Bid/Contract, a written explanation of why such certification cannot be made.
- b. The Contractor also certifies, in writing, that as of the date of its execution of this Bid/Contract it has no tax liabilities or other Commonwealth obligations, or has filed a timely administrative or judicial appeal if such liabilities or obligations exist, or is subject to a duly approved deferred payment plan if such liabilities exist.
- c. The Contractor's obligations pursuant to these provisions are ongoing from and after the effective date of the Contract through the termination date thereof. Accordingly, the Contractor shall have an obligation to inform the Commonwealth if, at any time during the term of the Contract, it becomes delinquent in the payment of taxes, or other Commonwealth obligations, or if it or, to the best knowledge of the Contractor, any of its subcontractors are suspended or debarred by the Commonwealth, the federal government, or any other state or governmental entity. Such notification shall be made within 15 days of the date of suspension or debarment.

- d. The failure of the Contractor to notify the Commonwealth of its suspension or debarment by the Commonwealth, any other state, or the federal government shall constitute an event of default of the Contract with the Commonwealth.
- e. The Contractor agrees to reimburse the Commonwealth for the reasonable costs of investigation incurred by the Office of State Inspector General for investigations of the Contractor's compliance with the terms of this or any other agreement between the Contractor and the Commonwealth that results in the suspension or debarment of the contractor. Such costs shall include, but shall not be limited to, salaries of investigators, including overtime; travel and lodging expenses; and expert witness and documentary fees. The Contractor shall not be responsible for investigative costs for investigations that do not result in the Contractor's suspension or debarment.
- f. The Contractor may obtain current list of suspended and debarred Commonwealth contractors by either searching the Internet at <http://www.dgs.state.pa.us/debarment.htm> or contacting the:

Department of General Services
Office of Chief Counsel
603 North Office Building
Harrisburg, PA 17125
Telephone No: (717) 783-6472
FAX No: (717) 787-9138

35. **Offset Provisions.** The word "Contractor" as used herein shall refer to Lessor. The Contractor agrees that the Commonwealth of Pennsylvania (the "Commonwealth") may set off the amount of any state tax liability or other obligation of the Contractor or its subsidiaries to the Commonwealth against any payments due the Contractor under any contract with the Commonwealth.
36. **Nondiscrimination/Sexual Harassment Clause.** The word "Contractor" as used herein shall refer to Lessor. The Contractor agrees:
- a. In the hiring of any employee(s) for the performance of work, or any other activity required under the contract, or any subcontract, subcontract, the Contractor, subcontractor, or any person acting on behalf of the Contractor or subcontractor shall not, by reason of gender, race, creed, or color, discriminate against any citizen of this Commonwealth who is qualified and available to perform the work to which the employment relates.
 - b. Neither the Contractor nor any subcontractor nor any person on their behalf shall in any manner discriminate against or intimidate any employee involved in the performance of work, or any other activity required under the contract on account of gender, race, creed, or color.
 - c. The Contractor and any subcontractors shall establish and maintain a written sexual harassment policy and shall inform their employees of the policy. The policy must contain a notice that sexual harassment will not be tolerated and employees who practice it will be disciplined.
 - d. The Contractor and any subcontractors shall not discriminate by reason of gender, race, creed, or color against any subcontractor or supplier who is qualified to perform the work to which the contracts relates.
 - e. The Contractor and each subcontractor shall furnish all necessary employment documents and records and permit access to their books, records, and accounts by the contracting agency and the Bureau of Small Business Opportunities ("BSBO") for purpose of ascertaining compliance with provisions of this Nondiscrimination/Sexual Harassment Clause. If the Contractor or any subcontractor does not possess documents or records reflecting the necessary information requested, the Contractor or subcontractor shall furnish such information on reporting forms supplied by the contracting agency or the BSBO.
 - f. The Contractor shall include the provisions of this Nondiscrimination/Sexual Harassment Clause in every subcontract so that those provisions applicable to subcontractors will be binding upon each subcontractor.
 - g. The Commonwealth may cancel or terminate the contract and all money due or to become due under the contract may be forfeited for a violation of the terms and conditions of this

Nondiscrimination/Sexual Harassment Clause. In addition, the agency may proceed with debarment or suspension and may place Contractor in the Contractor Responsibility File.

37. **Notice.** Any notice or demand from Lessee to Lessor or from Lessor to Lessee shall be in writing and shall be delivered by hand or by deposit in United States mail, postage prepaid, via registered or certified mail. If the Notice is to the Lessor, it should be placed in an envelope addressed to the attention of the Lessor Contact identified on the Lease Cover Sheet. If the Notice is to the Lessee, it should be placed in an envelope addressed to the attention of:

Director
Bureau of Real Estate
Department of General Services
503 North Office Building
Harrisburg, Pennsylvania 17125

37. **Events of Default.** Any one or more of the following events shall constitute an "Event of Default":

- a. Failure of Lessor to provide the services as stipulated in this Lease without disruption or interruption.
- b. Failure of Lessor to maintain the Premises in a safe and tenantable condition.
- c. Failure of Lessor to provide peaceful and uninterrupted possession of the Premises by Lessee.
- d. Failure of Lessor to perform or observe any obligations set forth in this Lease.
- e. Failure of Lessor to notify Lessee of Lease Assignments prior to receiving Lessee's written approval to assign the Lease.
- f. Failure of Lessor to perform or observe any of the other covenants, terms or conditions contained in this Lease within thirty (30) days after written notice by Lessee.

38. **Remedies of Lessee.** Upon the occurrence and continuance of an Event of Default by Lessor, Lessee may, after giving Lessor thirty (30) days' written notice, except as modified as forth herein, exercise one or more of the following remedies:

- a. If any Event of Default by Lessor results in a material disruption in Lessee's business operations at the Premises of longer than twenty four (24) hours and Lessee notified Lessor of the material disruption in Lessee's business operation with a request to cure within a shorter time period of thirty (30) days as to ensure that Lessee does not continue to experience disruption in their business operations and Lessor fails to cure within any such shorter time period stated in said notice, then Lessee may cure, with written notice to the Lessor, the Event of Default, which is a material disruption in Lessee's business operations, at Lessor's sole cost and expense.
 - i. Lessor shall reimburse Lessee for their reasonable costs and expenses, including but not limited to costs incurred due to a temporary move of Lessee, in connection with Lessee curing the Event of Default together with interest on the amount of such costs and expenses, including but not limited to costs incurred for any and all temporary relocation(s), as a result of the Event of Default, of Lessee, at a rate of ten percent (10%) per annum from the date such costs and expenses were incurred.
 - ii. Such reimbursement shall be made within ten (10) days after Lessor receives an invoice from Lessee detailing the costs and expenses of the cure.
 - iii. If Lessor fails to pay the Lessee the full amount, as evidenced in the invoice from Lessee, within ten (10) days after receipt of the invoice, then Lessee shall have the right to set off the full amount due to Lessee against the Rent.
 - iv. Lessor shall continue to be liable to Lessee for any amounts Lessee elects not to offset against Rent.

- b. If an Event of Default poses a risk of material injury or damage to persons or property, and a cure is reasonably necessary to prevent material injury or damage to persons or property, and Lessee so notifies Lessor of this risk and the necessity to cure within a shorter time period of thirty (30) days, and Lessor fails to commence its cure within any such shorter time period stated in said notice to prevent material injury or damage, then Lessee may, after written notice to Lessor, cure the Event of Default which poses a risk of material injury or damage to persons or property.
 - i. Lessor shall reimburse Lessee for their reasonable costs and expenses, including but not limited to costs incurred due to a temporary move of Lessee, in connection with Lessee curing the Event of Default together with interest on the amount of such costs and expenses, including but not limited to costs incurred for any and all temporary relocation(s), as a result of the Event of Default, of Lessee, at a rate of ten percent (10%) per annum from the date such costs and expenses were incurred.
 - ii. Such reimbursement shall be made within ten (10) days after Lessor receives an invoice from Lessee detailing the costs and expenses of the cure.
 - iii. If Lessor fails to pay the Lessee the full amount, as evidenced in the invoice from Lessee, within ten (10) days after receipt of the invoice, then Lessee shall have the right to set off the full amount due to Lessee against the Rent.
 - iv. Lessor shall continue to be liable to Lessee for any amounts Lessee elects not to offset against Rent.
 - c. Lessee shall not be liable to Lessor for the manner in which Lessee performs Lessor's obligations under this Paragraph, and Lessor releases Lessee of any liability of any nature related to such performance.
 - d. Lessee's performance of a Lessor obligation under this Paragraph shall not relieve Lessor from thereafter performing that obligation.
 - e. Terminate this Lease and the tenancy created hereby.
 - f. Abate payment of Rent as long as the Event of Default remains in effect. After corrective action has been completed by Lessor, Lessee shall pay Lessor the withheld Rent less any costs and expenses, including but not limited to, costs incurred for any and all temporary relocation(s) of Lessee, as a result of the Event of Default suffered by Lessee.
 - g. The thirty (30) day notice requirement imposed by Lessee in this Paragraph does not apply where the Event of Default results in Lessee's vacating the Premises. In such an event, the Lessor's thirty (30) day period to cure begins immediately upon the occurrence of the Event of Default notwithstanding that Lessor's written default notice may be sent subsequent to the occurrence of the Event of Default.
 - h. Notwithstanding the last sentence of this Paragraph, Lessee, in its sole discretion, may immediately and permanently abate Rent for the period Lessee is constructively evicted from the Premises.
 - i. Notwithstanding any other provision of this Lease, Lessee in its sole discretion may terminate this Lease and the tenancy created hereby in the event there are three or more Events of Default within any three-hundred sixty-five (365) day period, regardless of whether Lessor cures the defaults in accordance with this Paragraph.
 - j. The remedies of Lessee set forth in this Paragraph shall be in addition to all other remedies available at law or equity to Lessee for any default by Lessor under this Lease.
39. **No Waiver of Rights.** The failure by Lessee to require performance of any provision of this Lease shall not affect Lessee's right to require performance at any time thereafter. Further, a waiver of any breach or default of this Lease shall not constitute a waiver of any subsequent breach or default or a waiver of the provision itself.

40. **Disputes.**

- a. In the event of a controversy or claim arising from the Lease,
 - i. Lessor shall, within six (6) months after the cause of action accrues, file a written claim with the Director of the Bureau of Real Estate, Department of General Services, for a determination. The claim shall state all grounds upon which Lessor asserts a dispute exists.
 - ii. If Lessor fails to file a claim or files an untimely claim, Lessor acknowledges and agrees that they have waived their right to assert a claim in any forum.
- b. At the time the claim is filed, or within sixty (60) days thereafter, either party may request mediation through the Commonwealth Office of General Counsel Dispute Resolution Program.
 - i. If Lessor or the Director of the Bureau of Real Estate requests mediation and the other party agrees, the Director of the Bureau of Real Estate shall promptly make arrangements for mediation.
 - ii. Mediation shall be scheduled so as to not delay the issuance of the final determination beyond the required one hundred twenty (120) days after receipt of the claim if mediation is unsuccessful.
- c. If mediation is not agreed to or if a resolution is not reached through mediation, the Director of the Bureau of Real Estate shall review any timely-filed claim and issue a final determination, in writing, regarding the claim.
- d. The final determination shall be issued within one hundred twenty (120) days of the receipt of the claim, unless extended by consent of Lessee and the Lessor. The Director of the Bureau of Real Estate shall send his/her written determination to Lessor.
 - i. If the Director of the Bureau of Real Estate fails to issue a final determination within one hundred twenty (120) days (unless extended by consent of the parties), the claim shall be deemed denied.
 - ii. The determination of the Director of the Bureau of Real Estate shall be the final order of the Department of General Services.
- e. Within fifteen (15) days of the mailing date of the determination denying a claim, or within one hundred thirty five (135) days of filing a claim, if no extension is agreed to by the parties, whichever occurs first, Lessor may file a statement of claim with the Commonwealth Board of Claims.
- f. Pending a final judicial resolution of a controversy or claim, Lessor shall proceed diligently with the performance of this Lease in a manner consistent with the determination of the Director of the Bureau of Real Estate.
- g. Notwithstanding anything herein to the contrary, Lessee expressly reserves its rights to file any claim against Lessor in any forum of their choice including, but not limited to, the Commonwealth Board of Claims, Commonwealth Court, Dauphin County, or any other county court, and the U.S. District Court for the Middle District of Pennsylvania.

41. **Attachments and Exhibits Part of Lease.** Included in and made a part of this Lease, with the same force and effect as though fully set forth in this Lease are the following attached Attachments and Exhibits:

ATTACHMENTS:

Attachment A – Lease Standard Terms and Conditions

Exhibit 1 – Acceptance of Leased Premises Inspection Report

Exhibit 2 – Consent Form

Exhibit 3 -- Asbestos Certification

Exhibit 4 -- Prevailing Minimum Wages

Attachment B –Commonwealth of Pennsylvania Standard Building Specifications

Attachment C –Commonwealth of Pennsylvania Using Agency Building Specifications

42. **Modifications to the Lease.** This Lease may not be modified orally and supersedes all prior agreements and understandings, both written and oral, between the parties with respect to this Lease. Any and all modifications to the Lease must be done by Lease Amendment that is signed by both parties and approved by the Board of Commissioners of Public Grounds and Buildings, the Secretary of the Department of General Services, or via Consent Form.
43. **Interpretation.** This Lease shall be construed and interpreted in accordance with the laws of the Commonwealth of Pennsylvania.
44. **Review of Lease.** The parties acknowledge that each party and its respective counsel have reviewed this Lease and that no rule of construction to the effect that any ambiguities are to be resolved against the drafting party shall be employed in the interpretation of this Lease or any amendment or Exhibits hereto.
45. **Execution.** Lessor agrees and acknowledges that this Lease is subject to final execution by the Secretary of the Department of General Services and approval by the Board of Commissioners of Public Grounds and Buildings.
46. **Time is of the Essence.** Time is of the essence of all provisions of the Lease, including all Notice Provisions, to be performed by or on behalf of Lessor and Lessee.
47. **Binding Successors and Assigns.** All rights and liabilities herein given to, or imposed upon, the respective parties hereto shall extend to and bind the several respective successors and permitted assigns of the parties.
48. **Survival.** The expiration of the Term, whether by lapse of time or otherwise, shall not relieve either party of any obligations which accrued prior to, or which may continue to accrue, after the expiration of or early termination of this Lease.
49. **Conflict Between Lease Terms and Conditions and Specifications.** To the extent that there are any conflicts among the Lease Cover Sheet, these **Attachment A** Lease Standard Terms and Conditions, the Commonwealth of Pennsylvania Standard Building Specifications set forth in **Attachment B**, and/or the Commonwealth of Pennsylvania Using Agency Building Specifications set forth in **Attachment C**, Lessor shall maintain/construct the Premises in accordance with the most stringent standard.
50. **Integration.** This Lease, including all referenced Attachments and Exhibits, constitutes the entire agreement between the parties. No agent, representative, employee, or officer of Lessor or Lessee has the authority to make, or has made, any statement, agreement, or representation, oral or written, in connection with this Lease, which in any way can be deemed to modify, add to, or detract from, or otherwise change or alter its terms and conditions. No negotiations between the parties, nor any custom or usage, shall be permitted to modify or contradict any of the terms and conditions of this Lease. No modifications, alterations, changes, or waiver to this Lease or any of its terms shall be valid or binding unless accomplished by a written amendment or Consent Form signed by both parties, consistent with Paragraph 41, "Attachments and Exhibits Part of Lease" and Paragraph 42, "Modifications to the Lease".

EXHIBIT 1

Acceptance of Leased Premises and/or Renovations Inspection
Report (GSRR-42-N (08-13))

ACCEPTANCE OF LEASED PREMISES AND/OR RENOVATIONS
INSPECTION REPORT
EXHIBIT "1"

LESSOR: _____
(NAME)

(STREET) (CITY) (COUNTY)

LOCATION: _____
(STREET) (CITY) (COUNTY)

USING AGENCY: _____
(DEPARTMENT) (BUREAU)

This is to certify that I have visually inspected the above premises on _____
(DATE)

and find that the premises are built and/or renovated in accordance with the requirements of

Lease _____,
(LEASE #)

with the exception of the following items:

1. _____
2. _____
3. _____
4. _____
5. _____
6. _____

(Additional items on attached sheet, if necessary)

The _____ hereby accepts the above premises for occupancy
(USING AGENCY)
effective _____ and approves the _____ New Construction _____ Renovations
(ACCEPTANCE DATE)

excepting the above items numbered _____

Further, _____ agrees that _____
(USING AGENCY) (ACCEPTANCE DATE)

is to be the effective date of occupancy; that the rental for the above mentioned property shall commence on that
date, that the lease term, upon the execution of this document by all parties, shall extend for _____ years
from the acceptance date; with any option terms provided for in the lease being adjusted accordingly.

(USING AGENCY'S REPRESENTATIVE)

(TITLE)

(USING AGENCY)

I understand and agree to the foregoing and I certify, as lessor of the above referenced premises, that
completion of the excepted items as stated herein shall be no later than _____. I also
acknowledge _____

and agree that, should I fail to complete any of those items within the above time frame, then the (USING
AGENCY) _____ may at its discretion withhold rental payments.

I hereby agree to the adjustment in the lease and option terms described above.

(LESSOR)

Copy to DGS _____
DATE

Copy to Treasury _____

EXHIBIT 2

Leasehold Improvement Consent Form

EXHIBIT "2"
CONSENT FORM

SPC NO.

LEASE #

LESSOR:

LESSEE:

Property
Address:

The LESSOR of the above-referenced property hereby consents and otherwise authorizes the LESSEE to make leasehold improvements to the leased premises as per attached plans and specifications.

The total cost of the leasehold improvements is estimated at \$ _____ and this cost will be borne in full by the LESSEE.

The LESSOR understands and agrees that the items installed by LESSEE shall remain the property of the Commonwealth and non-fixture items may be removed by the LESSEE provided that the leased premises are restored to their original condition, ordinary wear and tear excepted.

The LESSOR, through its duly authorized officers, hereby executes this consent form this _____ day of _____, 20____. Individual and/or Partnership

Witness

Lessor

Corporation

Lessor - Corporate Name

Secretary/Treasurer

President/Vice President

"FOR DGS USE ONLY"

Reviewed By: _____ Date

- Approved
 - Disapproved
- (See Attached)

EXHIBIT 3

Asbestos Certification

ASBESTOS CERTIFICATE
Exhibit "3"

1. LESSOR certifies that an asbestos survey has been completed relative to the entire building in which the space is located in accordance with the following criteria:

a. Building(s) must be inspected by PAL&I-certified inspector(s), each with a minimum of one (1) year experience in conducting building inspections for asbestos-containing materials (ACM).

b. Samples must be collected and analyzed in numbers no less stringent than AHERA guidelines.

c. Sample analysis must be performed by laboratory(ies) accredited under the NVLAP program for asbestos bulk sample analysis.

d. All suspect materials must be analyzed for asbestos, except for the following:

- 1. Roofing materials**
- 2. Undamaged firedoors**
- 3. Exterior siding**

e. Suspect materials not analyzed must be reported as "assumed-ACM".

f. Physical and hazard assessments of all ACM and assumed-ACM must be performed by PAL&I-certified management planner(s), each with a minimum of one year experience in preparing management plans for ACM in buildings.

Two complete copies of the management plan, including a completed Table C-1, must be submitted to LESSEE for review prior to the issuance of a LEASE. The management plan must include copies of all bulk sample analysis results, floor plans or diagrams indicating the location of all ACM and assumed-ACM, and explicit recommendations for each area of ACM found or assumed. Table C-1 must list all materials tested or assumed, regardless of the results. For materials verified by laboratory analysis to be non-ACM, only the first four (4) columns of Table C-1 must be completed.

2. LESSOR agrees that any and all recommendations made by the professional preparing the above management plan to repair, remove, encapsulate, or otherwise abate any or all ACM or assumed-ACM in the building(s) will be completed prior to occupancy by LESSEE. As a minimum requirement, all ACM or assumed-ACM with any degree of

damage must be restored to an undamaged condition prior to occupancy of the PREMISES by LESSEE. LESSEE will not be responsible for any expenses incurred in complying with the recommended actions, or for LEASE payments prior to occupancy. This work must be completed in accordance with the following criteria:

a. LESSOR will notify LESSEE of all asbestos-related work, in writing, at least twenty (20) days prior to commencement of such work. When responding to emergency situation, notification to the LESSEE must occur as soon as possible, but no later than 12 hours after commencement of the work.

b. Abatement contractor must be PAL&I-certified as a contractor and have a minimum of two (2) years experience in performing asbestos abatement work.

c. Workers must be PAL&I-certified as asbestos abatement workers.

d. Workers must be supervised by a PAL&I-certified abatement supervisor with a minimum of one (1) year experience in asbestos abatement.

e. The services of an independent consulting firm must be retained during the course of abatement to monitor the contractor's performance, conduct air monitoring both inside and outside of critical barriers each day abatement is conducted, and conduct clearance testing.

f. Daily air monitoring will consist of collecting a minimum of two (2) samples inside, and two (2) outside, each individual work area. Sample volume must exceed 1800 liters and analysis should be by phase contrast microscopy using NIOSH 7400 performed by an AIHA-accredited laboratory. Analysis results greater than or equal to .01 fibers per cubic centimeter for samples collected outside of the critical barriers will require prompt action on the part of the LESSOR, at the LESSOR'S sole cost, to protect LESSEE'S employees health and safety.

g. For clearance testing of projects involving the disturbance of a quantity of ACM or assumed-ACM less than or equal to 160 square feet of 260 linear feet, five (5) samples must be collected and analyzed by phase contrast microscopy using NIOSH 7400 performed by an AIHA-accredited laboratory. The volume of each sample must exceed 1800 liters. Analysis results greater than or equal to .01 fibers per cubic centimeter for any of the samples will result in failure of the testing, and will require recleaning until all five (5) sample results are less than .01 fibers per cubic centimeter.

h. For clearance testing of projects involving the disturbance of a quantity of ACM or assumed-ACM greater than 160 square feet of 260 linear feet, the guidelines of 40 CFR Part 763, Subpart E, Appendix A, Section IV (Mandatory Interpretation of Transmission Electron Microscopy Results to Determine Completion of Response Actions) shall apply.

i. Verbal results of clearance monitoring following abatement must be provided to LESSEE prior to removal of primary barriers. In addition, copies of all air monitoring results and hygienist's reports must be delivered to LESSEE within thirty (30) days following completion of any abatement action.

This work must be completed, and written certification by the LESSOR'S consultant provided, within thirty (30) days prior to the date LESSEE would otherwise take possession of the PREMISES. LESSEE may elect to terminate this LEASE by written notice to the LESSOR if these requirements are not met.

3. LESSOR further agrees that during the period of time that the building(s) contains damaged ACM or damaged assumed-ACM in any form, air monitoring will be conducted at approximately one (1) month intervals, at the LESSOR'S sole expense. Air monitoring shall begin within seventy two (72) hours following discovery by, or notification to, the LESSOR that damaged ACM or damaged assumed-ACM exists. One sample for each 10,000 square feet of floor area must be collected, with a minimum of three (3) samples collected and analyzed per air monitoring interval. Sample volume must exceed 1800 liters and analysis should be by phase contrast microscopy using NIOSH 7400 or equivalent performed by an AIHA-accredited laboratory. Verbal results of air monitoring must be provided to LESSEE within forty eight (48) hours of the laboratory's notification to the LESSOR, with copies of the written laboratory report to follow within fifteen (15) days. Analysis results greater than or equal to .01 fibers per cubic centimeter in any sample will require action, within forty eight (48) hours, on the part of the LESSOR and at the LESSOR'S sole cost, to protect LESSEE'S employees by undertaking during non-working hours the following:

a. Repair all damaged ACM and damaged assumed-ACM, and remove all debris suspected of containing asbestos.

b. Remove and replace damaged ACM and damaged assumed-ACM with other appropriate building materials and restore the building to a safe condition, or

c. Encapsulate, enclose, encase, or other appropriate containment method on the damaged ACM and damaged assumed-ACM.

This work must be completed in compliance with the criteria listed in Section 2. In addition to the LESSOR'S testing responsibility, LESSEE retains the right to collect any samples and conduct any testing.

Regardless of air monitoring results, all damaged ACM and damaged assumed-ACM must be repaired to abated within sixty (60) days from the date of discovery by, or notification to, the LESSOR. If the required repairs or abatement is not completed within this time period, LESSEE may either terminate this LEASE immediately without prior notice, or make any changes, repairs, and alterations LESSEE deems necessary to protect the health and safety of its employees.

4. LESSEE shall be entitled to claim from LESSOR all consequential damages arising out of LESSOR'S breach of warranty and representations contained in this Exhibit. Furthermore, if LESSEE or its agents repair or abate ACM and assumed-ACM pursuant to this Exhibit, LESSOR shall reimburse LESSEE, within fifteen (15) days, for all costs and expenses associated therewith, including, but not limited to costs of repair, abatement and disposal of ACM and assumed-ACM, costs of restoration, costs of air quality and materials testing and analysis, relocation and incremental rental expenses, and related fees of consultants and experts.

LESSOR agrees to abide by all applicable Federal, State, and Local regulations. LESSOR further agrees to protect, indemnify and save harmless LESSEE from and against any and all liabilities, losses, damages, costs, expenses, causes of action, suits, claims, demands or judgments of any nature arising from any injuries to, or death of any person growing out of or connected with the presence of asbestos in the demised PREMISES.

EXHIBIT 4

Prevailing Minimum Wages

APPENDIX B
COMMONWEALTH OF PENNSYLVANIA
REQUIRED DOCUMENTS

1. GSRE-19 Proposal to Lease Space to the Commonwealth
2. GSRE-6 Lessor Identity Disclosure (*see attached instructions*)
3. GSRE-47 Agency Agreement/Limited Agent Authority
4. GSRE-42M Contractor Responsibility Certification
5. GSRE-54 Notice – Bureau of Real Estate is Sole Agent for the Commonwealth
6. GSRE-63 Acknowledgment/Useable Area Definition
7. GSRE-64 Consent to Release or Obtain Information and Contact Professional References (*see attached instructions*)

Forms listed above are available electronically at the link below

<http://www.portal.state.pa.us/portal/server.pt?open=512&objID=1346&&SortOrder=100&level=2&parentid=1231&css=L2&mode=2&cached=true>

8. Prevailing Wage Pre-determination from the Department of Labor and Industry (*go to http://www.dli.state.pa.us/landi/li_apps/requestPW.asp and request the prevailing wages. See attached instructions and Page 6 of this SFP for additional information*)

Commonwealth of Pennsylvania

Department of General Services

Bureau of Real Estate

INSTRUCTIONS FOR LESSOR IDENTITY DISCLOSURE AND CONSENT TO RELEASE OR OBTAIN INFORMATION AND CONTACT PROFESSIONAL REFERENCES

Who Must Fill Out Lessor Identity Disclosure and Consent to Release...

- The Corporation
- Individuals owning 30 percent or more of a Corporation or Limited Liability Company
- Partnership owning 30 percent or more of the Partnership
- Limited Liability Partnership owning 30 percent or more of the Partnership
- Sole Proprietor/Co-Owner
- Authority
- Borough, City, Trust or other entity

How Should You Complete Both Forms

- Type or legibly print your EIN, Name and Address in spaces provided
- A separate Consent to Release form must be completed for every corporation/individual that is listed on the Lessor Identity Disclosure form.
- There are two Attachments 1 (please return one and retain the other for your records)
- Return Attachment 2

Questions

- Contact your Real Estate Coordinator at (717) 787-4394

How to submit information for a Prevailing Wage Determination

1. On the Internet go to the PA Department of Labor and Industry Homepage.

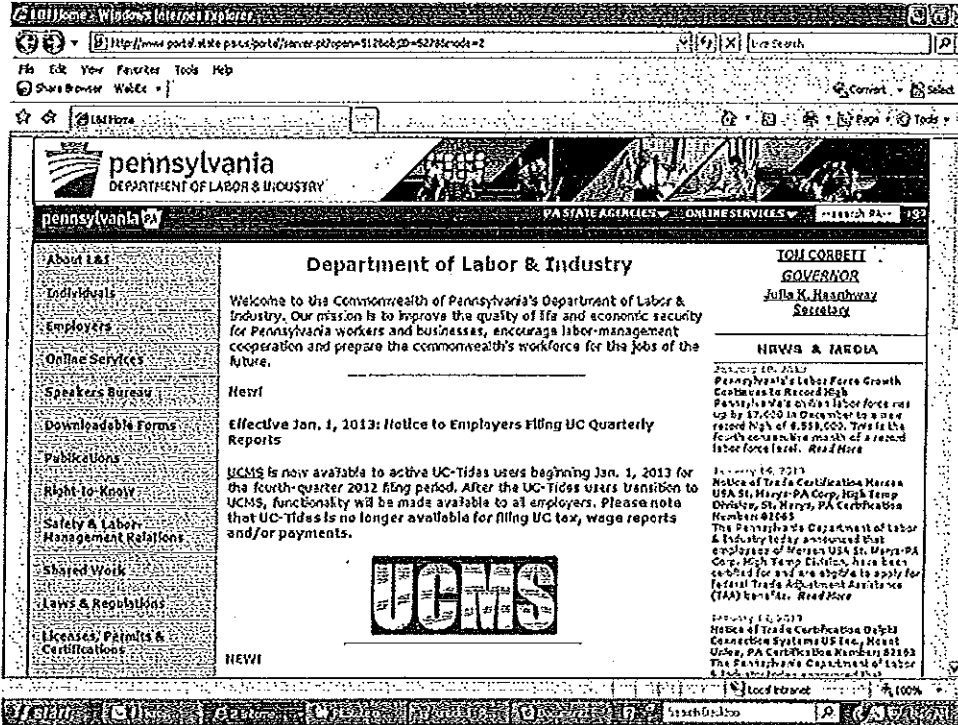

2. Scroll down and select "Labor Law Compliance".

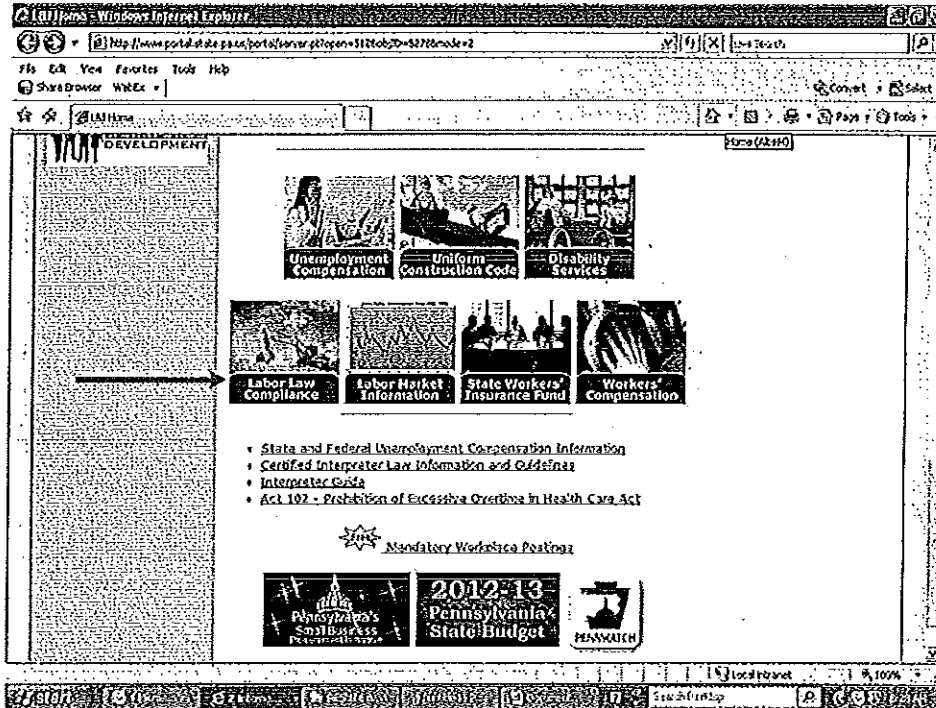

3. Select Prevailing Wage Act

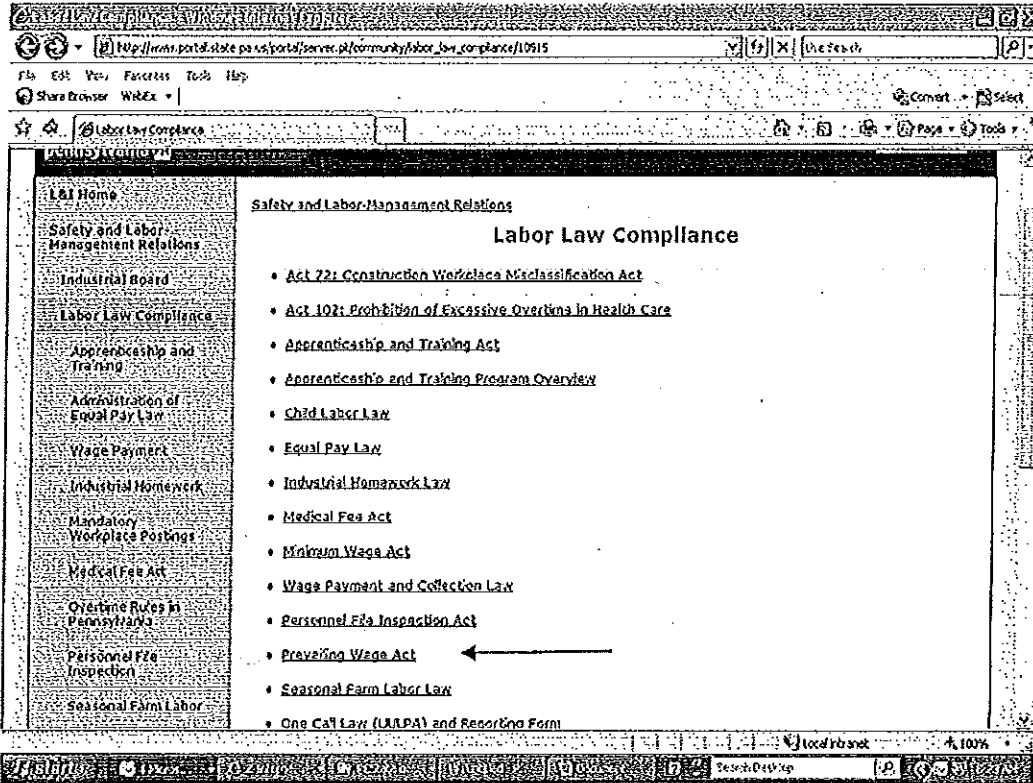

4. Select Online Prevailing Wage Application & Rate Search

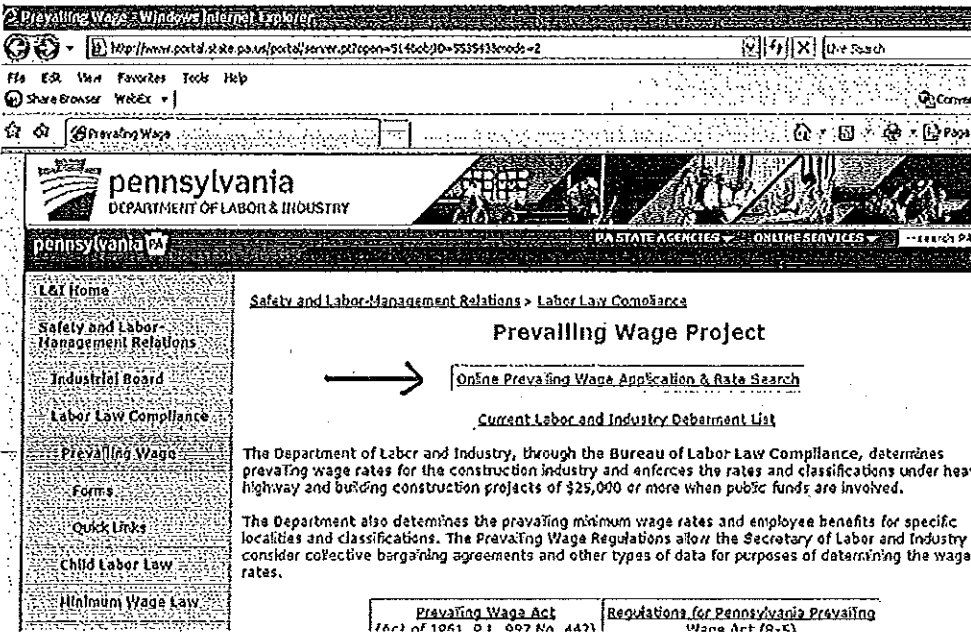

5. Select Prevailing Wage Rates Determination Request Form

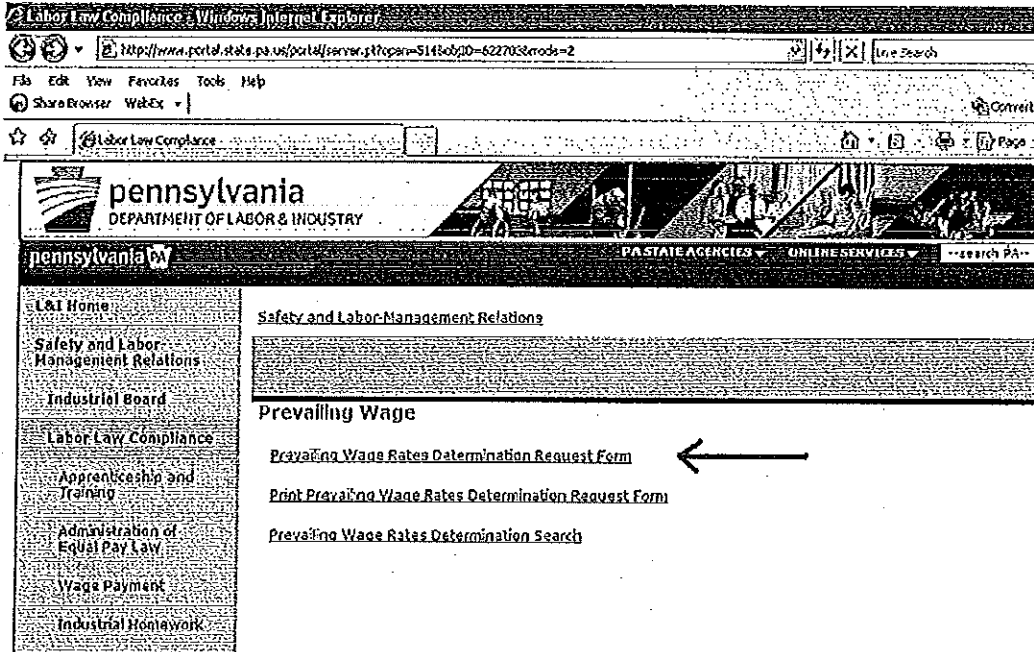

6. The form below will be pulled up. Follow directions to complete and submit.

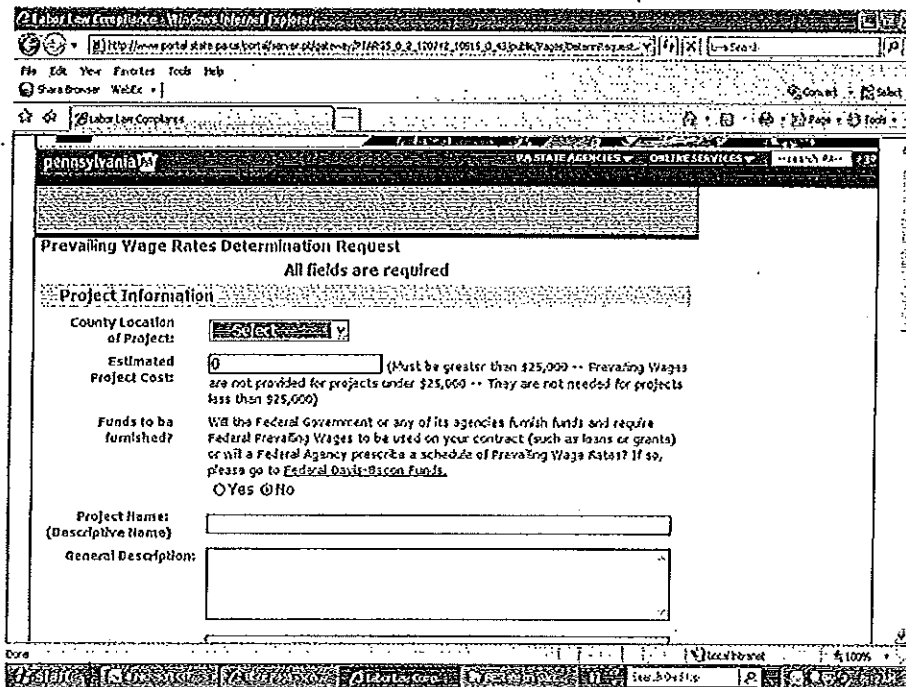

APPENDIX C

**COMMONWEALTH OF PENNSYLVANIA STANDARD
BUILDING SPECIFICATIONS
AND USING AGENCY SPECIFICATIONS**

ATTACHMENT B

COMMONWEALTH OF PENNSYLVANIA
STANDARD BUILDING CONSTRUCTION SPECIFICATIONS

Table of Contents

BUILDING AREA (SOLE TENANCY BY THE COMMONWEALTH)	5
FLOOR OR SUITE AREA (MULTI-TENANT BUILDING).....	5
SPECIFICATION CONFLICT	5
GENERAL SPECIFICATIONS	5
APPROVALS	5
BRAND NAMES.....	6
SECTION A. EXTERIOR/SITE WORK.....	6
FOUNDATIONS	6
EXTERIOR WALLS.....	6
ROOF CONSTRUCTION, MAINTENANCE & REPAIR	6
CONCRETE WALKS AND CURBS.....	6
ENTRANCES AND APPROACHES	6
SECTION B. INTERIOR DESIGN.....	6
OFFICE LAYOUT DESIGN SPECIFICATIONS.....	6
OFFICE DESIGN COLOR COORDINATION.....	7
COLUMNS.....	7
VESTIBULES AND EXITS	7
SECTION C. INTERIOR CONSTRUCTION	7
WALLS	7
WALL FURRING.....	7
INTERIOR PARTITIONS.....	7
INTERIOR WALLS (paint)	7
WINDOWS.....	7
WINDOW COVERINGS.....	8
DOORS.....	8
INTERIOR DOORS	8
ENTRANCE / EXIT DOORS AND FRAMES	8
DOOR HARDWARE	8
LOCKS	8
FINISH HARDWARE.....	8
SIGNAGE -INTERIOR ROOM DOORS AND WORKSTATIONS	8
SECTION D. FINISHES.....	8

CEILING AND CEILING TILE	8
FLOOR AND FLOOR COVERINGS	9
MODULAR CARPET	9
TILE	9
SECTION E. ENTRANCES AND EXITS	9
SECTION F. HVAC – SPECIFICATIONS & REQUIREMENTS	9
GENERAL DESCRIPTION	10
TEMPERATURES	10
FALL AND SPRING CHANGEOVER	10
RELATIVE HUMIDITY	10
ZONING REQUIREMENTS	10
SUPPLY FAN OPERATION	10
GROUND FLOOR PERIMETER HEAT	10
DUCTWORK	11
FILTRATION	11
ECONOMIZER – ENTHALPY CONTROLLED	11
EXHAUST/VENTILATION SYSTEMS	11
TOILET ROOM AND JANITOR CLOSET EXHAUST	11
TELECOMMUNICATIONS ROOM EXHAUST	12
REQUIRED DOCUMENTATION	12
SECTION G. PLUMBING AND TOILET SPECIFICATIONS	12
GENERAL	12
PIPING	12
FIXTURES	13
FIXTURES PER FLOOR	13
TOILET PARTITIONS	13
JANITOR’S CLOSET	13
EXHAUST SYSTEMS	13
WATER HYDRANTS	14
CONSUMABLES	14
SECTION H. ELECTRICAL SPECIFICATIONS	14
GENERAL	14
OTHER ELECTRICAL REQUIREMENTS	14

LIGHTING 15

 MINIMUM LIGHTING LEVELS 15

POWER 15

 TELE-POWER POLES (in lieu of under floor duct system when approved by LESSEE) 15

SECTION I. SPECIAL SYSTEMS 16

 FIRE ALARM 16

SECTION J. MISCELLANEOUS SPECIFICATIONS 16

SECTION K. VOICE/DATA REQUIREMENTS 16

SECTION L. JANITORIAL 16

SECTION M. DIAGRAMS 16

Office space must be located out of/or higher than the 100 year flood plain. Downtown building sites as defined by the Downtown Location Act that are considered to be properly rehabilitated to meet the requirements of these specifications will be given preference in site selection.

This project must be completed within 180 days of the Using Agency approving the project documents (consisting of detailed plans, specifications, drawings and other relevant construction documents). Therefore, the LESSOR shall pay the LESSEE, as liquidated damages, in the amount of 2% of the annual rental of this Lease for each and every day the premises are not ready for occupancy by the Using Agency beyond the 180 day period specified above.

BUILDING AREA (SOLE TENANCY BY THE COMMONWEALTH)

The building area shall be computed by measuring the inside finished surface of all permanent and major walls excluding stairwells or fire towers, utility spaces, elevator and escalator shafts, mechanical and building equipment rooms, public restrooms and any area used by the LESSOR.

FLOOR OR SUITE AREA (MULTI-TENANT BUILDING)

The floor or office suite area shall be computed by measuring the inside finished surface of the office side of corridors and other permanent walls, to the inside wall or partitions that separate the office from adjoining no-leased, usable areas, and to the finished surface of the dominant portion of the permanent outer building walls excluding stairwells, elevator and escalator shafts, mechanical and building equipment rooms, common lobbies, hallways and corridors, and public restrooms that serve the entire building.

SPECIFICATION CONFLICT

In the event of any conflict between the Commonwealth Standard Building Construction Specifications (Attachment B) and the Using Agency Building Specifications (Attachment C), the higher or most stringent requirements shall prevail.

GENERAL SPECIFICATIONS

No construction shall begin until after the lease has been awarded and a "pre-construction" meeting held. A construction schedule/critical path plan identifying significant milestones must be provided by LESSOR at the pre-construction meeting and finalized within thirty (30) days after the pre-construction meeting. LESSOR shall provide written construction updates to an Agency-designated project liaison and shall timely respond to all reasonable additional requests for clarification or further information made by the liaison. The requirements of this paragraph are in addition to and do not replace or supersede any other reporting requirements or deadlines set forth in the lease. LESSOR shall submit three copies of floor plan drawings and a CAD drawing on disk on which are located all building columns, and windows, doors, and stairways from which a preliminary office layout can be developed. This is due within thirty days of site selection notification. Prior to the first scheduled pre-construction meeting, and prior to any erection, adaptation, remodeling or alteration of any building, three copies of detailed architectural drawings, including but not limited to, elevation drawings, mechanical drawings showing the HVAC system, together with detailed specifications, shall be submitted to the Department of General Services (DGS), Bureau of Real Estate (BRE) for final review. After final drawings have been approved by the DGS, BRE and Using Agency, changes can only be made through prior written approval from the DGS, BRE. LESSOR will furnish all labor and material necessary to complete construction shown on approved drawings and described in the approved specifications, and for any work not included in approved drawings and specifications but necessary to complete construction and make the space ready for occupancy by the Using Agency.

APPROVALS

Before any building is erected, adapted, remodeled or altered, detailed architectural plans and elevations for all new construction, all remodeling or alteration work, and line drawings to 1/8 inch scale (1/8 inch = 1 foot scale) for all other portions of the buildings showing means of egress, shall be submitted to and approved by the enforcing municipality or the Department of Labor and Industry for compliance with the PA Uniform Construction Code (UCC). A UCC Certificate of Occupancy issued by the enforcing municipality or the Department of Labor and Industry is required prior to occupancy. Any variations from these specifications MUST have the approval of the DGS, BRE. The LESSOR must be able to substantiate that he has obtained said approval. Once the drawings have received all approvals, a disk with the CAD drawing should be sent to the DGS, BRE. A construction schedule must be submitted to the DGS, BRE and a pre-construction meeting must be held prior to any construction commencing.

BRAND NAMES

The citation of brand names and model numbers throughout this document is intended only to define the standard of the article being described and is not intended to be proprietary. The DGS, BRE will consider any manufacturer's products so long as they are equal in quality to the brands cited, at its sole discretion.

SECTION A. EXTERIOR/SITE WORK

FOUNDATIONS

All foundations must be constructed of sufficient size and strength and placed on load-bearing-soil of sufficient compactness to carry the weight of the building components and all equipment. The concrete for the foundations shall be reinforced where necessary and be homogenous and when hardened, shall have the required strength, resistance to deterioration, durability, resistance to abrasion, water tightness, appearance and other required properties.

EXTERIOR WALLS

All exposed exterior walls must be of masonry or wood frame construction with brick, stone or metal facing material and be approved by the LESSEE.

ROOF CONSTRUCTION, MAINTENANCE & REPAIR

For the life of the lease, a roofing maintenance contract must be maintained with a certified roofing contractor. Service response times must be within 24 hours of notification by LESSEE. Prior to occupancy, at the LESSEE's sole discretion and as a required condition of acceptance of the leased premises, the roof must be inspected by an independent contractor approved by DGS, BRE and at the sole cost of the LESSOR. The final report from the independent contractor must be submitted to DGS, BRE no later than two weeks after inspection. Workmanship and material shall be first class in every respect and sheet metal work erected shall be installed so as to obtain an absolutely watertight job. Suitable provision shall be made for free expansion and contraction without disturbing the metal and causing leaks. The roof must have a first class vapor barrier and insulation which shall be installed in accordance with the current printed recommendations of the manufacturer of the roofing materials. A copy of the recommendation must be submitted to DGS, BRE by the LESSOR advising that the installation shall completely conform to the specifications being forwarded. In the event the roof shall need to be repaired, the LESSOR must engage a certified roofing contractor to evaluate the roof and provide a detailed report to the LESSOR and to DGS, BRE delineating the problems and recommended solution within 30 business days. In the event that there is water damage to the LESSEE's property due to deficiencies with the roof, the LESSOR shall be responsible to clean, repair, and/or replace said property and relocate any affected staff at the sole cost of the LESSOR.

CONCRETE WALKS AND CURBS

Installation and construction of concrete walks and curbs shall conform to the current requirements of the Pennsylvania Department of Transportation (PENNDOT), including the installation of stone fill under the sidewalk. All sidewalks shall be reinforced as architecturally designed. Sidewalks shall be constructed in separate slabs, and these slabs shall be separated by 1/4" thick transverse control joints at 6' intervals. Walks must be kept free from snow, ice and debris.

ENTRANCES AND APPROACHES

Approaches to entrances and exits must be concrete construction and reinforced as architecturally designed. Where ramps are deemed necessary from the entrance or exit to the sidewalk or street level, they must meet current ADA regulations. Handrails must be provided along the ramps.

SECTION B. INTERIOR DESIGN

OFFICE LAYOUT DESIGN SPECIFICATIONS

These specifications are developed to identify the requirements of various areas of the office. Where necessary, detail drawings are included. A final approved plan will be prepared by the LESSEE, which will show the individual areas, electrical requirements, telephone requirements, and computer related requirements.

OFFICE DESIGN COLOR COORDINATION

Floor covering, wall covering, counter surfaces, and window treatments will be color-coordinated within a harmony of color as designated by LESSEE. LESSOR will be required to work with the LESSEE's designee in developing the integration of the harmony of colors throughout the office. LESSEE will make color selection of all finish materials: i.e., as wall coverings, carpet, laminated services, paint, Venetian blinds, trim, etc. LESSOR to provide manufacturer samples to LESSEE to make selections.

COLUMNS

The building should be free of all interior columns. In the event columns are deemed necessary, the number and spacing of columns must be approved by the LESSEE. Columns shall be finished with material to correspond with interior decor approved by the LESSEE complete with one (minimum) duplex electrical outlet.

VESTIBULES AND EXITS

Inside walls of vestibules and exits must be covered with scuff resistant material, 4'6" in height. Weather mats must be furnished by LESSOR and installed in entrances and exits. Mats must be inspected on a monthly basis and replaced when they become unserviceable (worn, torn, etc) or at the request of the LESSEE.

SECTION C. INTERIOR CONSTRUCTION

WALLS

WALL FURRING

Unless agreed upon otherwise, all interior brick, tile, or concrete block walls are to be furred out with metal, wood, or other materials acceptable and approved by LESSEE, constructed from floor to ceiling height and insulated. The furring must be of suitable type and size to support the weight of the interior finishing.

INTERIOR PARTITIONS

All interior partitions must be minimum 5/8" thick drywall or gypsum board and erected in accordance with the floor plan. The amount, size and configuration of all interior partitions will be determined by LESSEE during the project design phase. Any rooms designated by LESSEE, must be sound resistant construction. Studding for the sound-resistant rooms must be erected above the acoustical ceiling. The following method of construction is suggested: Wall studding must be treated to eliminate sound transmission. Sound deadening board must be provided from the floor plate and over the ceiling panels to assure sound reduction. All interior partitions and doors must be erected in accordance with the drawings agreed to at the pre-construction meeting. If requested by LESSEE, LESSOR will install a chair rail of approximately 3" width, and at a height of 36" from the floor, in rooms specified by LESSEE. The quantity, size, configuration and location of private offices to be constructed by the LESSOR will be determined by LESSEE in the design phase of the project. If LESSEE selects any modular furniture for use in the leased premises, LESSOR agrees to assist and coordinate with LESSEE's modular furniture-vendor(s) the installation of same and coordinate any required electrical, data and voice installation.

INTERIOR WALLS (paint)

Portions of the building to receive drywall designated to be painted shall receive finishes prior to occupancy. Walls shall be prepared and painted with semi-gloss latex Polomyx paint in at least a four-color mix or LESSEE approved equivalent. Paint shall be a solvent-free, water-based, and non-VOC emitting paint.

Immediately after occupancy, LESSOR will refinish marred walls during normal business hours unless otherwise requested by LESSEE. Color selection to be approved by the LESSEE.

WINDOWS

Window locations must be acceptable to LESSEE and provide a maximum of natural light. All windows must be inoperable. Windows must be made to comply with all industry standards and be certified to meet the requirements for deflection, air infiltration, and water penetration by complying with all ASTM performance and test standards. All windows must be supplied with insulating glass or other energy-conserving installations approved by LESSEE.

WINDOW COVERINGS

Window and window areas must be equipped with aluminum or vinyl Venetian blinds or draperies or other coverings approved by LESSEE. Color and materials to be approved by LESSEE.

DOORS

INTERIOR DOORS

Solid core wooden doors or equivalent must be at least 36" wide and 1 ¾" thick and be equipped with kick plates and push plates where requested by the LESSEE. They must be reinforced and warp resistant, carefully matched grain, and color and must meet all specifications of the National Woodwork Manufacturers Association. Interior entrances/exit door dimensions and lights shall meet requirement of Life Safety Code #101. LESSOR agrees to furnish and install visibility windows, 4" by 24", in interior doors as required by LESSEE.

ENTRANCE / EXIT DOORS AND FRAMES

Entrance doors must be provided as shown on drawings. They must swing outward and be constructed of metal and glass to conform with Federal, state, and NFPA 101 codes and standards. They must be equipped with kick plates, push-pull plates, and automatic door closers. Door frames must be of the same metal to match the doors.

Interior vestibule doors must be provided in all public and staff entrances and vestibule doors must match exterior doors and be equipped with kick plates, push-pull plates, and automatic door closing devices. All exit doors must swing outward. Framework must be metal constructed and must match exterior doors.

DOOR HARDWARE

All entrance and exit door hardware must be of suitable type and ample size and weight to perform the service of high-frequency use. The hardware must be of one design and finish. All entrance and exit doors must be keyed alike. Install a delayed action door closer at the handicap entrance, which should be tested annually and adjusted, as needed. Panic hardware must be installed on emergency exits in accordance with Department of Labor and Industry and the IBC Codes and Regulations. All door operations and hardware must meet ADA Standards.

LOCKS

Door locks are required on all interiors doors. All doors must remain on the Building Master Key System. A sufficient number of Master Keys must be provided to the LESSEE.

FINISH HARDWARE

Sufficient commercial grade hardware to cover all necessary requirements of the building shall be provided. It shall be of suitable type and ample size and weight to perform the service requirements. The hardware must be one design and finish. All interior door locks shall be keyed per the Using Agency Specifications and the Using Agency shall be provided a sufficient number of keys as required by the Using Agency. All door locks must remain on the Building Master Key Lock System

SIGNAGE -INTERIOR ROOM DOORS AND WORKSTATIONS

Interior room doors and workstations must be lettered or have name plates attached as required by the LESSEE. LESSEE will provide a "door-lettering" schedule for the interior doors and workstations.

SECTION D. FINISHES

CEILING AND CEILING TILE

All ceilings shall be acoustical tile suspended by an intermediate duty suspension grid system unless the exposed interior shell and structural system comprise an acceptable interior environment that does not need a suspended ceiling system for acceptable aesthetic, acoustic and lighting requirements. Any exposed mechanical and electrical elements are acceptable if in accordance with codes and if treated in an aesthetic manner and approved by LESSEE. Acoustical tile and grid system for ceilings shall be selected to reduce energy costs and provide sustainable design. All ceilings shall be at least 9 feet in height above finish flooring, unless a lower dimension is approved by LESSEE. Acoustical products shall have a Class-A fire resistance per ASTM E 1264 and a flame spread of 0-25 per ASTM E 84 and must have a minimum of

50% post consumer recycled content. Ceiling tiles shall have a 89% minimum light reflectance with a minimum NRC of .70 in compliance with ASTM C 423 and a CAC minimum of 35 in compliance with ASTM E 1414, such as the Ultima Hi-LR series as manufactured by Armstrong World Industries, Inc. or LESSEE approved equal. Ceiling(s) in the telecommunication/data room(s) must be provided with acoustical tile on a suspension grid system. Stained or damaged ceiling tiles must be replaced immediately by the LESSOR for the life of the Lease.

FLOOR AND FLOOR COVERINGS

For newly constructed buildings, 4" of coarse aggregate is to be spread throughout proposed floor area. Polyethylene waterproofing material, or equivalent, shall be used as a vapor barrier between aggregate and concrete. Newly poured concrete floors must cure for the full 28 days before any floor coverings can be applied. Floor areas to consist of a minimum of 4". Floor should be properly insulated against heat, if over boiler, or other highly heated areas. Where no heat is in a basement, appropriate insulation should be installed to minimize cold or dampness coming through the floor. If floor is otherwise constructed or existing floor is used, floor must be leveled and properly insulated prior to installation of covering.

MODULAR CARPET

Carpeting material tiles (18" x 18" or 24" x 24", etc.) shall be made of 100% commercial grade nylon fiber 6 or 6.6 which is solution dyed with EPA approved anti-microbial protection and be 100% recyclable to an equal or tufted multi-level loop, 9.0-9.5 stitches per inch, static resistance of 1.0 KVS, and a minimum denier of 6000. The carpet tiles must have a minimum 15-year wear manufactured by Collins and Aikman, or LESSEE-approved equal, which has Green Seal's recommendation or certification. Color of carpeting shall be subject to approval by LESSEE. All doors in carpet area shall be undercut sufficiently to permit free swing. Carpeting must conform to Federal Occupational Safety and Health Regulations concerning fireproofing. Carpet tiles shall be replaced during the term and option period as needed and where normal wear and tear so requires, as requested by the LESSEE. Any variation from above must have prior approval from the LESSEE. Where necessary, all modular carpeting must be vacuumed and shampooed before occupancy as deemed necessary by LESSEE. All unserviceable carpeting will be replaced by the LESSOR (i.e. worn, torn, stained, loose or frayed) as determined by the LESSEE throughout the term of the lease at the request of the LESSEE. At any time during the term of the lease when the carpet is replaced or repaired, the moving of the LESSEE's furniture and equipment, with the exception of computers, monitors and related equipment, shall be the responsibility of the LESSOR.

TILE

The entry, waiting, stock, janitorial, utility and lunch rooms shall be covered with a vinyl composition tile or other materials approved by LESSEE. Tile shall be 12" x 12" – 1/8" gauge. SS-T 312B (1) Type IV, Composition 1 - ASTM E 84 Flame Spread - 75 or less. Load limit 50 PSL. Cove base shall be 4" high vinyl or rubber. All colors and patterns shall be selected by LESSEE. LESSOR to provide manufacturer samples to the LESSEE.

SECTION E. ENTRANCES AND EXITS

Refer to the Using Agency Building Specifications (Attachment C)

SECTION F. HVAC – SPECIFICATIONS & REQUIREMENTS

The LESSEE expects the developers to use these specifications as a guide when dealing with their architects and engineers on the design of proposed office space. In some cases, the HVAC design will result in packaged-zoned VAV style systems, or in the case of smaller buildings, a zoned roof top / split DX type of system with zone dampers. Heating may be provided by several sources such as electric resistance, hydronic or gas fired equipment. All aspects of the proposed building should be of good quality with sound and durable construction. Furthermore, the building HVAC system should require minimal maintenance, allow for cleaning/service, and have low operating costs.

Mechanical engineering drawings shall be provided to the LESSEE for review and approval. The drawing scale shall be no less than 1/8" = 1'. Cut sheet information on equipment should be supplied and model selection should be clearly marked. All equipment shall be of a commercial grade and industrial grade equipment can be submitted for approval. Residential grade equipment shall not be used. If possible, the HVAC equipment and temperature controls shall be furnished as a complete package and warranted as a factory tested system by the equipment manufacturer. When temperature controls are not supplied with factory HVAC equipment, the temperature control systems shall be made by a nationally recognized manufacturer with an established chain of factory authorized installation representatives. All

temperature control systems shall be LON or BACnet compliant systems. The design and installation of the HVAC system shall conform to the following list of codes and standards: 2006 International Mechanical Code, S.M.A.C.N.A., A.S.H.R.A.E., N.E.C., I.B.C., N.F.P.A.

GENERAL DESCRIPTION

The HVAC system should provide adequate capacity, airflow distribution, and temperature control. The HVAC shall also provide the proper cooling, heating, exhaust, and ventilation of the various spaces, while meeting the design criteria listed herein after. Construction should comply with all sections of the International Building Code. If any air-handling unit has a supply air of 2000cfm or greater, install duct mounted smoke detector(s) according to the International Mechanical Code (I.M.C.) Section 606. If duct smoke detectors are required, they should be monitored by the building fire alarm system and should shut-down the air-handling unit supply fan. During the occupied period ventilation shall be provided, the outdoor air quantity shall not be less than 15% of the total maximum air supply CFM quantity, nor less than 20 cfm per occupant, whichever is greater. If a variable air volume system is installed, the 20 cfm/occupant of outdoor air shall be maintained at the minimum zone control settings.

TEMPERATURES

Air Conditioning System must provide and maintain an inside automatically controlled temperature of 75°F dry bulb +/-2°F dry bulb in summer. Heating System must provide and maintain an inside automatically controlled temperature of 67°F dry bulb +/-2°F dry bulb in winter. The building shall be set no less than 67°F in winter and no greater than 75°F in summer during the occupied hours of the building as per the Commonwealth Management Directive 720.5. These unoccupied temperature limits can be eliminated if the controls are furnished with optimum start-stop logic. If used, the start-stop logic will start HVAC equipment operations automatically and will adjust to allow the building to reach the occupied temperature set points at the start of the day, regardless of the outdoor temperatures. However, if the optimum start-stop logic cannot compensate and cannot maintain occupied temperature set points at the start of the occupied period, then the occupied temperature limits will be imposed during the unoccupied period.

FALL AND SPRING CHANGEOVER

Adjustments shall be made as necessary to effect optimal temperature in the occupied space. Temperature below 67°F dry bulb or above 75°F dry bulb under any conditions will be considered in violation of lease conditions.

RELATIVE HUMIDITY

Relative Humidity shall be maintained at 40-60% where practical.

ZONING REQUIREMENTS

The HVAC system shall be designed to allow for zone control in the manner specified herein. Independently controlled zones shall exist for each lunchroom, training rooms, conference rooms, and waiting/lobby/reception area. For larger open areas, separate and independently controlled zones should be used for each of the north, south, east, and west zones or perimeter walls. Zone dampers with respective wall mounted zone thermostats can be utilized to provide additional zone temperature control. Private offices should be zoned and controlled independent of open office areas. Because of the heat generated from electronic equipment, the Telecommunication / Server rooms need a dedicated independent cooling system. These systems can be simplistic and can be manufactured with independent self contained temperature controls. Small HVAC systems, such as a mini-split DX cooling or heat pump units can be installed to handle the high equipment cooling loads.

SUPPLY FAN OPERATION

In the cooling mode, continuous fan operation during the occupied cycle is required to meet outdoor ventilation code requirements (Reference the 2006 IMC – Section 403 & Table 403.3. & ASHRAE 62-2007.) Temperature control can be achieved by allowing by-pass air, or controlling total cooling capacity by cycling and staging the compressors, or discharge air temperature reset, or adjusting chilled water temperature. In the heating mode, continuous fan operation is required to maintain ventilation code requirements. Therefore, the heat shall be staged at the central unit as much as practical to minimize unheated air being circulated. If a VAV system is utilized, supply air can be re-heated at each respective zone at the VAV at minimum air-flow conditions. If a more conventional air system is utilized, the room temperature shall be maintained by modulating the zone damper via the zone thermostat.

GROUND FLOOR PERIMETER HEAT

On the ground floor of a building without a basement (slab on grade construction) that has large glass windows, additional perimeter supplemental heat may be required. (Exemption from providing this additional perimeter heating should be

formally requested to the DGS, BRE.) Perimeter heating will be provided to improve occupant comfort in areas with large windows and increased heating loads. Installation of either perimeter electric baseboard heat, hot water/fin-tube or hot water radiant floors shall be provided for the full length under windows. HVAC systems which utilize ductwork to provide heating can utilize slot style air diffuser over windows in place of the additional perimeter heat, to deal with increased heat loss through windows. The baseboard/fin-tube required heat may be controlled by the zone thermostat or an independent thermostat with interlocking to prevent operation in summer.

DUCTWORK

All ductwork shall be fabricated of galvanized sheet metal designed and installed in accordance with the SMACNA HVAC DUCT CONSTRUCTION STANDARDS for 2 inches W.G. static pressure for duct mains, and 1 inch W.G. static pressure for branch ducts. Reference the 2006 IMC – Section 600. Reference the 2006 IMC for Smoke Detection Systems Control – Section 606. All supply and return ductwork shall be externally insulated with fiberglass wrap or fiberglass board insulation of not less than 2 inches thick with external foil wrap barrier. Ductwork constructed of fiberglass duct board or internally insulated sheet metal ductwork shall not be used, even if allowed by code. Internal insulation used on discharge air metal ductwork, needed for the sound control of air handling units, shall be acceptable. The ductwork shall be adequately and properly designed to prevent unobtrusive noise levels in the occupied space using turning vanes on 90° turns. Insulated flex duct up to 8 feet in length may be used from the branch duct to the air diffuser. Flex ductwork shall be supported as per current S.M.A.C.N.A. – HVAC DUCT CONSTRUCTION STANDARDS. (Flex-duct shall not rest on top of drop-in ceiling grid system.) Air diffusers shall be sized for each space to provide proper air throw, but shall produce minimal air noise. Each diffuser shall have an integral adjustable damper to control air flow. The air diffusers utilized shall be designed for the HVAC system application. The air diffusers can be constructed of metal or PVC, and should be easy to clean and tolerant to moisture. Upon the completion of construction and before occupancy, the HVAC system shall be air balanced by a TABB certified air balancing contractor. Full documentation of the test results shall be provided to the DGS, BRE for review and acceptance.

FILTRATION

All heating, ventilation and air conditioning systems shall be a polyester pre-filter of a minimum 2-inch thickness and 30% efficiency installed in the system. The pre-filter shall be installed in the system in a location that all air handled by the system will pass through the pre-filter prior to distribution into the work areas and public areas. The filters are to be replaced and/or washed at least every three months or more often as dictated by operating conditions or as recommended by the manufacturer. During replacement/cleaning operations, the HVAC system shall be completely shut off to avoid distribution of unwanted particulate through the system. Reference section 605 of the 2006 IMC.

ECONOMIZER – ENTHALPY CONTROLLED

The HVAC unit shall be designed to allow for free cooling utilizing 100% outdoor air when the conditions are appropriate. When required, the building air relief shall be provided by a powered vent in the unit to prevent building over pressurization during the economizer cycle. As a minimum, the outside air damper will modulate to provide a CFM quantity equal to 15% (20 cfm/occupant) of the supply air CFM during the occupied period. Humidity control shall be maintained

EXHAUST/VENTILATION SYSTEMS

Exhaust systems shall be provided for the ventilation of conference rooms, multi-purpose rooms, staff rooms, lunch rooms, toilet rooms and janitor closets and telecommunication room. Exhaust fans for these areas shall be sized to match or exceed the outside air ventilation rate. (Reference the 2006 IMC – Section 403 & Table 403.3. & ASHRAE 62-2007) All exhaust fans shall be of commercial grade and shall discharge outdoors either through roof mounted fans or wall vents. At no time will exhaust fans discharge to the ceiling plenum nor within 10 feet of any air intakes or operable windows. Exhaust fans shall operate continuously during office hours except for the conference room and multi-purpose room. The Telecommunication Room shall be equipped with an exhaust system being controlled by an electronic thermostat with an “ON” set point of 80°F. The fans shall be selected for the design airflow or not less than 0.25 inches static pressure, whichever is greater. At no time shall the sound level of the exhaust system exceed NC 30 when measured from within the room. If ceiling exhausters are used, they shall be selected to operate below four zones at the design conditions. The proper operation of all exhaust fans shall be verified quarterly.

TOILET ROOM AND JANITOR CLOSET EXHAUST

The toilet rooms and janitorial closet shall be provided with an exhaust rate equal to 5 air changes per hour or as dictated by local codes, whichever is greater. A common exhaust system for the men’ and women’s toilet rooms shall be provided

with a minimum of 4 elbows between exhaust grills to minimize noise carryover. The exhaust grills shall be of the egg crate variety with minimum 3/8 inch spacing to minimize clogging of the air stream.

TELECOMMUNICATIONS ROOM EXHAUST

The HVAC environmental comfort shall be maintained the same as the general office area (see Section E, Temperatures). A wall mounted digital display thermometer shall be installed.

REQUIRED DOCUMENTATION

LESSOR shall provide to the LESSEE the following documentation of the HVAC design:

- Mechanical Engineering Drawing Requirements
 - Numbered drawings.
 - Scaled drawings (1/8" = 1'-0" minimum) showing the layout of all HVAC equipment to be installed.
 - Building location related to North (North Arrow).
 - Room names describing the use of the space.
 - Mechanical symbols list.
 - Abbreviations list.
 - Complete title block information.
 - Scaled ductwork layout with CFM, size, and zone outline information.
 - HVAC equipment schedules showing at least equipment name, CFM (outside, return, and supply), cooling/heating capacities.
 - A roof plan (if needed), showing equipment name and location.
 - Indicate space thermostat locations, relative to zones being controlled.
 - Mechanical drawings with installation details.
 - Written sequence of operations for all HVAC systems.

- HVAC Design Requirements
 - If flexible ductwork is used, show size and length (not to exceed 8 feet).
 - If applicable, provide supplemental heat for entranceways, foyers, stair towers, lobbies, and perimeter heat for ground floor window locations.
 - If applicable, show duct smoke detector locations on air handling equipment.
 - Provide additional ventilation for the telecommunication rooms by way of a direct acting space thermostat and exhaust fan.
 - Include cut sheet information on all equipment used as a basis of design.
 - Include outdoor air calculations/method (ASHRAE 62) for all areas.
 - Include heating & cooling load calculations.
 - Provide an Air Balance Report – TABB Certified

SECTION G. PLUMBING AND TOILET SPECIFICATIONS

GENERAL

All plumbing lines, valves, and equipment shall be high grade institutional quality capable of providing trouble free service for the number of employees specified in the SFP. The building shall comply with all local and state plumbing regulations including those which apply to handicapped access. The plumbing installation must be completely approved cold and hot water piping system with valve connections and a complete sanitary drainage system to all rest rooms, janitor's closet, employees' room, equipment or utility room and to all water consuming equipment.

PIPING

Piping below grade (more than 5' outside building) shall be set in ASCE bedding, with carefully compacted stone bedding and selected compacted backfill to an elevation 6" above top of pipe. Sanitary sewer shall be service weight cast iron hub and spigot, lead and oakum or elastomeric joints, cast iron fittings or PVC gravity sewer pipe conforming to SDR-35 and ASTM D-3034 PVC fittings. Potable water piping shall be ductile cast iron, cement lined, mechanical joint ASTM A-377, Class 150, ANSI A21.51 and cast iron fittings ANSI A21.10 cement lined; or Class 150 ring-title PVC water pipe (SDR 13.5) ASTM D-2241, Product Standard PS 22-70 long term hydro of 4:1; or Type K copper. Storm sewer shall be same as sanitary sewer. Piping below grade (within 5' of building or under slab) shall be set in bedding and backfilled as

specified in paragraph above. The sanitary sewer shall be service weight cast iron hub and spigot with lead and oakum or elastomeric joint. Piping above grade including sanitary, waste, and vent system shall be cast iron, hub and spigot with lead and oakum or "no hub" or elastomeric compression type. Vents 2" or less may be galvanized steel, copper or PVC DWV system. The hot and cold water piping shall be Type L Hard, with wrought copper fitting. System shall be equipped with drain at low point and vent at high points. Provide shutoff valves at each cold and/or hot water connection to each fixture and at each branch connection. The water line servicing the building shall be valve and installed in an approved cast iron extension box. Clean outs shall be provided every 50' on horizontal drains and at the end of each horizontal branch.

FIXTURES

Choice of plumbing fixtures and hardware shall be limited to the following manufacturers and shall be water saver type; American Standard; Elger, Kohler. Lavatories shall be enameled cast iron minimum dimension 10" x 17". Hair interceptors shall be installed on all lavatories, inserted at the outlet. Water closets shall be vitreous china, wall hung or floor mount type and flush valve. Toilet accessories shall be stainless steel, recessed, as manufactured by Bobrick Washroom Equipment Inc., or equal. Restrooms shall be provided within the leased space for staff and sized in accordance with the Restroom Fixture Schedule within. The toilet fixture schedule specified below shall be determined by the architect by calculating the approximate percentage breakdown of men and women for each floor occupied by the agency, for each gender.

Lessor to install economically efficient dispensers for

FIXTURES PER FLOOR

Number of Men/Women	Water Closets	Lavatories
1-15	1	1
16-35	2	2
35-55	3	3
56-60	4	3
61-80	4	4
81-90	5	4
91-110	5	5
111-125	6	6
126-150	6	**
Over 150	***	

*In Men's facilities, urinals may be substituted for 1/3 of the water closet specified. One urinal equals 1/3 water closet. If urinals are installed, courtesy panel(s) must be installed between urinals and the urinal and lavatory.

**Add one lavatory for each 40 additional employees over 125.

***Add one water closet for each 40 additional employees over 150.

TOILET PARTITIONS

Provide metal toilet partitions as manufactured by Accurate Partitions Division, United States Gypsum Co., American Sanitary Partitions Corp., Global Steel Product Corp., or equal. Sheet steel shall be ASTM A591, Class C. galvanized-bonderized 20-gauge with pilaster shoes AISI Type 302/304, 20-gauge stainless steel, 3" high, finish shall match hardware. Furnish shoes at each pilaster. Manufacturer's standard, heavy-duty operating hardware and accessories, non-ferrous cast alloy with satin chrome finish.

JANITOR'S CLOSET

Janitor's closet must be equipped with deep slop basin. Open adjustable shelving must be installed adjacent to the slop sink. One section of wall will have a peg board installed. LESSOR to provide a variety box of peg board hardware. A minimum of one duplex electrical outlet is required.

EXHAUST SYSTEMS

Commercial grade exhaust fans, exhausted to the exterior, must be installed in all toilet rooms and janitor's closets.

WATER HYDRANTS

Anti-freeze type exterior water hydrants (key-type) must be installed with cold water piping-to exterior locations where they are readily accessible for use at all outside areas of the building.

CONSUMABLES

Economically efficient restroom fixtures for consumables to be provided and installed are: roll toilet tissue dispensers - one for each toilet; paper towel dispensers for C fold or multi-fold towels; toilet seat covers with dispenser; soap dispensers -self-contained type, one at each lavatory fixture; sanitary napkin waste receptacle - one for each ladies toilet; sanitary napkins and dispenser – one in each ladies toilet room.

All restroom consumables such as toilet tissue, paper towels, liquid hand soap, liners for sanitary napkin receptacles, sanitary napkins, liners for waste receptacles will be provided and replenished by the LESSOR.

SECTION H. ELECTRICAL SPECIFICATIONS

GENERAL

Provide electric service and metering facilities, panels, feeder wiring lighting, controls, receptacles, computer terminal cables, telephone cables and instrument outlets, wiring, conduit and raceways, and connections to mechanical equipment, security system, door signal system, fire alarm system, and emergency lighting system. Electrical service shall be received from the local utility at or be connected to 120/208-volt, 3Ø, 4-wire, 60-hertz. Metering facilities shall conform to local utility requirements. Electrical service may also be 277/480-volt, 3-phase, 60-hertz where the building would also have a step-down transformer to reduce the voltage from 277/480-volt to 120/208-volt where applicable building loads. Distribution and lighting panel boards shall be bolted circuit-breaker type panels with 3Ø main circuit breakers sized to withstand available short circuit currents. The panel boards shall have an adequate number of spare circuit slots to allow for future expansion. Feeder wiring to panels shall be type THHN insulated copper conductors run in electrical metallic tubing (EMT) or rigid steel conduit. Set screw-type fittings for EMT conduit are not to be used. Compression type fittings shall be utilized for EMT conduit. All electrical panels shall be grounded to a system grounding electrode. When adding any electrical equipment it must be grounded by means of equipment bonding jumper. Branch-circuits must also be connected to a grounding electrode. Wiring methods must comply with local codes and the National Electric Code (NFPA 70). All wiring shall be run concealed above ceilings, in walls and partitions and/or within modular furniture. Circuits shall be provided with a maximum of 1800 watts total on lighting circuits and eight duplex outlets maximum on receptacle circuits. All circuits to be 20-amp, No. 12-wire minimum. All branch circuit wiring to be copper conductors. Provide a suitable emergency lighting system which is in full compliance with all local and state codes and regulations. Emergency lighting will be required for space on each floor that exceeds 1,000 square feet.

OTHER ELECTRICAL REQUIREMENTS

Within the hallways throughout the office, a conventional duplex outlet will be installed approximately every 20' for use in building maintenance. In several areas within the office, additional conventional duplex outlets will be required for such equipment as postage meters, wall clocks, mail handling and photocopying equipment. This requirement should not exceed a total of 12 duplex outlets. One duplex receptacle is required for each photocopier location. The wiring must be home run with no more than one receptacle, no intermediate cut downs or splices, with the circuit terminating in the electric panel. Photocopiers may require 120-volt or 220-volt electric service. One Ground Fault Circuit Interrupter (GFCI) duplex receptacle is required in all client and staff restrooms. Isolated ground duplex receptacles wired for computer related usage will be located throughout the office. Refer to Note 2 in the Waiting Area requirements for details on isolated ground duplex receptacles. Duplex telecommunications jacks wired for voice and data will be located throughout the office for fax machines and printers. For purposes of these specifications in various areas of the office described herein, a conventional duplex outlet shall be a heavy-duty, specification grade duplex receptacle rated 20 amps, 125-volts, 2-pole, and 3-wire grounding. For purposes of these specifications in various areas of the office described herein, an isolated ground duplex outlet shall be a heavy-duty specification grade duplex orange receptacle rated 20-amps, 125-volts, 2-pole, and 3-wire grounding. Furnish duplex orange isolated ground receptacles as manufactured by Hubbell, Model IG5362, or approved equal. The isolated ground circuit shall be completed by running a dedicated insulated ground wire from the green grounding screw on the outlet to the system ground buss. The isolated ground outlet shall have an insulating barrier construction that isolates the ground contacts from the mounting strap. A pre-marked nylon cover-plate, Hubbell, Model PJ8C or approved equal, stamped "Computer Only" shall be provided for each isolated ground duplex outlet. A maximum of eight isolated ground duplex receptacles shall be connected on a computer related circuit.

LIGHTING

Lighting shall be provided for each space with individual space lighting controls. Circuit breakers are not to be used to control lighting units. Generally, a 2 foot x 4 foot lift out acoustical tile grid ceiling will be provided. Fluorescent "lay-in" fixtures shall be used using 2 foot x 4 foot, 1 foot x 4 foot and 2 foot x 2 foot shapes with acrylic plastic lenses. Use energy efficient watt-saver warm white 35-watt (change this to 32 or 28-watt) T-8 fluorescent lamps and electrical (use electronic in lieu of electrical) ballasts for all 48 inch lamps. The wattages can be reduced down to either 25- or 28-watt, energy-efficient T-8 lamps. Lighting levels shall be 70 foot candles (FC) maintained (using .7 maintenance factor) in all spaces except 25 FC in Toilets and Corridors, 30 FC in mechanical rooms and 35 FC in lunchroom. In general, the lighting schemes should avoid high contrast, scalloped patterns, or other visually distracting results. Lighting control technologies shall be installed to effectively combine the use of daylight and fluorescent lighting with daylight sensors and dimmable fluorescent ballasts in open office areas and lobbies. Occupancy sensors shall be installed to reduce energy consumption by switching off fixtures in unoccupied areas. Coordinate all spaces for occupancy sensor control with the LESSEE. Lighting controls shall be specification grade 20-amp, 120/277-volt quiet toggle switches with finish switch plates. Switches shall be provided, one per space minimum. In some areas such as small offices, bathrooms, conference rooms, etc., the use of occupancy sensor may be required in accordance with the PA Department of Labor & Industry standards per the Uniform Construction Code. The occupancy sensors may be ceiling-mounted or wall-mounted, depending on the size and application of the room. For occupancy sensors in bathrooms, it is recommended to use a dual technology sensor that utilizes passive infrared for motion and microphone detection for sound. Emergency lighting shall be provided in restrooms, common corridors and stairwells. Provide exterior lighting for walkways and signs as appropriate to the site. Exterior lighting shall be high intensity discharge (HID) illumination only such as High Pressure Sodium (HPS) and/or Metal Halide (MH) lighting fixtures. Lighting shall be controlled by time switches and photo cells. LESSOR shall provide, install and replace all light bulbs, lamps, ballasts and starters required throughout the term and all available option periods during the lease in all Commonwealth occupied space. All replacement lamps shall meet the above specification. Except where otherwise provided in this specification, lighting shall be designed in accordance with the American Standard Practice of the Illuminating Engineering Society of North America, ASNI/IESNA #RP-1-1995 or later revision.

MINIMUM LIGHTING LEVELS

Work Areas.....	Ambient 50 ft-candles (to be controlled by occupancy sensor)
Telecommunications	50 ft-candles (to be controlled by occupancy sensor)
Room(s)/Closet(s)	50 ft-candles (to be controlled by occupancy sensor)
Special Purpose Area(s)	75 ft-candles (to be controlled by occupancy sensor)
Hallway/Corridors	25 ft-candles
Conference/Meeting Rooms	30 – 70 ft-candles (using occupancy sensors and dimmable Fluorescent ballasts or split switching)
Mail Room and Restrooms.....	30 ft-candles (to be controlled by occupancy sensor)
Parking Lot Areas	1 ft-candle (parking lot/exterior lights shall be controlled by a programmable timer with an integrated photo cell controlled device)
Exit Lighting.....	LED-type fixture consuming no more than 2 watts per fixture

POWER

Receptacles in walls and partitions shall be specification grade 20-amp, 125-volt, grounded duplex receptacles. Receptacles shall be provided in each room or space and in accordance with floor plan. Receptacles on dedicated circuits for computers will be color coded for easy identification purposes. Wiring to modular furniture is described elsewhere in this specification. Receptacles for vending machines in the lunchroom shall be provided as required, but in no case, no less than four receptacles shall be provided. Provide all wiring and disconnect switches, and make all connections to mechanical equipment for heating ventilating, air conditioning, fire alarm, plumbing, sprinkler systems and other related systems and equipment using wiring methods described above.

TELE-POWER POLES (in lieu of under floor duct system when approved by LESSEE)

LESSOR to provide sufficient amount of Power Poles as required to accommodate the furniture plan. Furnish and install (where required) dual-channel tele-power poles to carry power circuits in one side and low potential communication circuits for telephone, intercom and other equipment in the other, fed directly from overhead raceway or other wiring system.

SECTION I. SPECIAL SYSTEMS

FIRE ALARM

The alarm system must contain all necessary alarm initiating devices such as early warning smoke detectors, heat detectors, and a manual pull station at every entrance/exit per floor. In addition, the alarm system shall contain all necessary audible (horns) and visual (strokes) notification appliances. The alarm system must annunciate at a central remote station upon activation. Provide, install, and maintain a dedicated (primary and secondary) voice analog/digital telephone line.

SECTION J. MISCELLANEOUS SPECIFICATIONS

Refer to the Using Agency Building Specifications (Attachment C)

SECTION K. VOICE/DATA REQUIREMENTS

Refer to Using Agency Building Specifications (Attachment C)

SECTION L. JANITORIAL

Refer to Using Agency Building Specifications (Attachment C)

SECTION M. DIAGRAMS

Refer to Using Agency Building Specifications (Attachment C)

ATTACHMENT C

COMMONWEALTH OF PENNSYLVANIA

USING AGENCY SPECIFICATIONS

DEPARTMENT OF HUMAN SERVICES

Table of Contents

- SECTION A. EXTERIOR / SITE WORK.....5
 - MAIL SLOT5
 - PARKING AREA (If provided).....5
- SECTION B. INTERIOR DESIGN5
 - OFFICE LAYOUT DESIGN5
 - WAITING AREA5
 - RECEPTION AREA5
 - GREETER STATION6
 - SELF-SERVICE TELEPHONE AREA6
 - SELF-SERVICE APPLICATION COUNTER6
 - CLIENT COMPUTER TERMINAL AREA (COMPASS)6
 - SELF-SERVICE COPIER AREA6
 - INTERVIEW BOOTH AREA6
 - ELECTRONIC BENEFITS TRANSFER (EBT)/DOCUMENT IMAGING AREA6
 - HEARING ROOM/DOMESTIC VIOLENCE ROOM(S)7
 - WORKSTATION AREA.....7
 - MODULAR FURNITURE7
 - MULTI-PURPOSE ROOM7
 - CONFERENCE ROOM(S)8
 - TRAINING ROOM(S)8
 - STOCK ROOM8
 - LUNCH ROOM8
 - COAT RACK(S)9
 - MAIL HANDLING AREA9
 - CENTRAL FILING AREA9
 - BULLETIN BOARDS9
 - PRIVATE OFFICES9
 - EXECUTIVE DIRECTOR9
 - MANAGERS.....9
 - OIG/ AUDITORS AREA..... 10
 - PASSENGER ELEVATORS (if applicable) 10
- SECTION C. INTERIOR CONSTRUCTION..... 10

SECTION D. FINISHES	10
FINISH SCHEDULE	10
SECTION E. ENTRANCES AND EXITS.....	11
VESTIBULE	11
CANOPY (if needed).....	11
CIGARETTE URN(S)	11
SECTION F. HVAC – SPECIFICATIONS & REQUIREMENTS	11
SECTION G. PLUMBING AND TOILET SPECIFICATIONS	11
STAFF RESTROOMS	11
PUBLIC RESTROOMS	12
ELECTRIC WATER COOLERS	12
SECTION H. ELECTRICAL SPECIFICATIONS.....	12
SECTION I. SPECIAL SYSTEMS	12
SECURITY SYSTEM	12
KEYLESS ENTRY DOOR	12
SECURITY PUSH BUTTON LOCKS	12
ELECTRONIC NUMBERING SYSTEM	13
INTERCOM PAGING SYSTEM	13
SECTION J. MISCELLANEOUS SPECIFICATIONS	13
FLOOR DIRECTORY (MULTI-TENANT BUILDINGS)	13
BUILDING IDENTIFICATION	13
PEST CONTROL	14
DESCRIPTION OF SERVICES.....	14
PESTS INCLUDED FOR PREVENTION AND/OR ELIMINATION.....	14
PESTICIDE APPLICATION	14
MANNER AND TIME TO CONDUCT SERVICES.....	14
STATE AGENCY RESPONSIBILITIES	15
RECORD KEEPING	15
SPECIAL REQUESTS AND EMERGENCY SERVICE(S)	15
SERVICE MAINTENANCE CONTRACTS.....	15
SECTION K. VOICE/DATA REQUIREMENTS	15
GENERAL REQUIREMENTS.....	16
TELECOMMUNICATIONS EQUIPMENT ROOM.....	16

TELECOMMUNICATIONS EQUIPMENT ROOM SIZE	17
MAIN CROSS CONNECTION (MC)	17
TELECOMMUNICATIONS EQUIPMENT PARTS LIST.....	18
VOICE REQUIREMENTS	18
DATA REQUIREMENTS.....	19
STATION WIRING	19
CONDUITS, POWER POLES AND PLENUM RUNS	19
JACKS	20
CODING, RECORDS, AND TRAINING	20
TESTING	20
TERMINATIONS AND WIRING DIAGRAM.....	21
DATA AND VOICE RACK LAYOUT	22
Small Office Layout.....	22
Large Office Layout.....	23
TELECOMMUNICATIONS ROOM LAYOUT.....	24
PATCH PANEL REQUIREMENTS.....	25
VOICE AND DATA CABLE T56B.....	25
VOICE AND DATA JACKS	25
INTERCOM PAGING SYSTEM	25
VOICE AND DATA REQUIREMENTS SUMMARY	25
CABLE RECORD	26
CABLE CERTIFICATION TESTING.....	26
SECTION L. JANITORIAL SCHEDULE.....	27
SECTION M. DIAGRAMS.....	30

SECTION A. EXTERIOR / SITE WORK

MAIL SLOT

An after-hours mail slot will be installed on an exterior door or wall near the front entrance and is the responsibility of the LESSOR. This mail slot will be for non-business hours. This area must be secure and contain a box inside the space to gather the documents dropped off.

PARKING AREA (If provided)

Paved parking preference is to be adjacent to the building, The accessible parking space(s) must be configured and appropriately marked in accordance with the Americans with Disabilities Act (ADA) standards. In addition, the space(s) must be appropriately identified in accordance with parking regulations contained in Section 3354(d) (3) (i) of the PA Vehicle Code. Reference R7-8 and R7-8B, Internet, PennDOT, Publications, Publication 35, Bulletin 15, (approved construction materials) Section 1103.04. Materials and workmanship shall conform to the latest applicable requirements of PennDOT Specifications. The paved parking area must be striped and numbered to provide the number of stalls specified. Cars must have free ingress and egress to parking stalls. Entrance and exit signs must be installed. Double-parking and blocked-in parking spaces may not be counted toward meeting minimum requirements. Furnish and install in locations as required, pre-cast concrete bumper guards. Metal stanchions with chain and lock should be provided at entrances and exits. Exit and entrance signs will be provided and appropriately located. Signage must be erected if requested and approved by DGS. LESSEE will provide the specifics. Provide exterior lighting for parking as appropriate to the site. Exterior lighting shall be high intensity discharge source illumination only. Lighting shall be controlled by time switches and photo cells. The LESSOR is responsible for furnishing and replacing all light tubes in parking area(s). LESSOR is responsible for painting initial lines and repainting as requested by the LESSEE. If parking is provided, it must meet the ADA required minimum number of accessible spaces (see chart below).

Total Parking in Lot	Required Minimum Number of Accessible Spaces
1 to 25	1
26 to 50	2
51 to 75	3
76 to 100	4
101 to 150	5
151 to 200	6
201 to 300	7
301 to 400	8
401 to 500	9
501 to 1000	2 percent of total
1001 and over	20 plus 1 for each 100 over 1000

SECTION B. INTERIOR DESIGN

OFFICE LAYOUT DESIGN

These specifications are developed to identify the requirements of various areas of the office. Where necessary, detail drawings are included.

WAITING AREA

An open area inside the main office entrance where clients are seated waiting for service. This area shall consist of approximately **720** square feet.

RECEPTION AREA

The reception area is the control center of the office where clients make the initial contact with staff for services. A detail of this area is below. The basic design will be the same for all offices but may increase in size by the number of staff assigned to this area. (See Diagrams #1, #2, #3)

The dimension drawing of the reception area shows several file cabinets under both the front counter and the return surfaces on each side. These cabinets will be supplied by the LESSEE. Lessor must provide a 28" clearance under all surfaces for the installation of this equipment.

This area must be wired to meet all voice/data & electrical requirements and is the responsibility of the LESSOR. The following specific requirements must be met.

- Front Counter Area
 - Two duplex electrical outlets on a common circuit.
 - Two duplex communication jack plates, each wired for voice and data.
 - Two duplex electrical outlets on a dedicated circuit for computer related use.
- Each Return Surface
 - One duplex outlet on a dedicated circuit for computer related use
 - One duplex communication jack plate wired for data

GREETER STATION ☒

This area shall consist of approximately **96** square feet. The Greeter Station is where clients will first interact with staff upon arrival. The Greeter Station will be located in the Client Waiting Area nearest the client entry to direct the flow of incoming traffic. This area must be wired to meet all voice, data and electrical requirements and is the responsibility of the LESSOR. Furniture to be provided by LESSEE.

SELF-SERVICE TELEPHONE AREA ☒

The Self-Service Telephone Area will be located in the Client Waiting Area. This area must be wired to accommodate **2** wall-mounted telephones. LESSOR to provide one 30" high x 24" wide counter with privacy shields approximately 20" high, to be evenly spaced between each telephone, which will create individual stations and ensure confidentiality to clients. Telephones to be provided by LESSEE.

SELF-SERVICE APPLICATION COUNTER ☒

The Self-Service Application Counter will be located in the Client Waiting Area. LESSOR to provide one 30" high x 24" wide and approximately 8' to 10' in length application-counter on one wall.

CLIENT COMPUTER TERMINAL AREA (COMPASS) ☒

The COMPASS Area will be located in the Client Waiting Area. This area must be situated so that a level of privacy and confidentiality is obtained while clients are completing online applications. This area must be wired to accommodate a minimum of **2** computer terminals and is the responsibility of the LESSOR. Furniture to be provided by LESSEE.

SELF-SERVICE COPIER AREA ☒

This area shall consist of approximately **27** square feet. The Self-Service Copier Area(s) will be located in the Client Waiting Area. This area must be large enough to accommodate a storage cabinet, a copier, and a drop box. This area must be wired to accommodate one copier and is the responsibility of the LESSOR. Furniture and equipment to be provided by LESSEE.

INTERVIEW BOOTH AREA ☒

This area shall consist of approximately **1004** square feet to accommodate **14** interview booths. This area is where staff conduct face-to-face interviews with clients. Panic button(s) to be provided and installed, which will alert staff in the Reception Area (wireless systems are permissible) and are the responsibility of the Lessor. Furniture to be provided by LESSEE. (See Diagram #5)

ELECTRONIC BENEFITS TRANSFER (EBT)/DOCUMENT IMAGING AREA ☒

Number of Booths: **1**. This area will be additional Customer Service Booth(s) located in the Client Waiting Area either at the end of a row of CSRs or in a private location away from the Waiting Area. Three duplex communication jacks wired for voice/data to accommodate special equipment are required for this area and is the

responsibility of the LESSOR. This area must also be wired to meet all voice/data and electrical requirements and is the responsibility of the LESSOR. Furniture to be provided by LESSEE.

HEARING ROOM/DOMESTIC VIOLENCE ROOM(S) ☒

Number of rooms required: **1**. These rooms shall consist of approximately **150** square feet each. These rooms(s) must be adjacent to the Client Waiting Area. Two doors must be provided for access to the space. One door to be provided entering from the Client Waiting Area, the other door to be provided entering from the staff work area. A shatterproof one-way 12"x12" window mounted at eye level must be provided in the door to the Client Waiting Area. Both doors must contain a peep hole and push button lock outside each entrance to the room(s), with keyed lock. Insulation for sound-proofing should be in walls and ceilings to the maximum extent possible. It is the responsibility of the Lessor to ensure these room(s) are wired to meet all voice/data & electrical requirements and is the responsibility of the LESSOR. Chair rail to be installed around the perimeter of the room(s) 36" from floor. Finish shall be natural and approximate color of interior doors. Furniture to be provided by LESSEE.

WORKSTATION AREA ☒

This area shall consist of approximately **6672** square feet to accommodate **127** workstations. (See Diagram #10)

MODULAR FURNITURE ☒

Each configuration of the modular units will be pre-wired by the furniture manufacturer to provide electrical service to each unit. Each modular unit must be wired to meet all voice/data & electrical requirements and is the responsibility of the LESSOR. Using Agency will supply either a pre-wired power pole or a base power in-feed, both of which have an extension of 60" in order to hardwire the electrical system to the building's electrical supply. It is the responsibility of the LESSOR to review the modular furniture configurations and determine the number of circuits required to meet national and local electrical codes. The LESSOR is also responsible for determining the entry points for bringing the voice/data wiring into the modular units as well as the hardwire locations with furniture supplier. If it is coming from a wall, column or floor; a base power in-feed will be utilized. Using Agency prefers this whenever possible. If the modular furniture is in an open area and not against columns or walls, then power poles will be utilized and the LESSOR will hardwire the connections in the ceiling. In wiring the system into the building's electrical supply, the isolated ground receptacle circuits shall have a dedicated insulated ground wire that is separate from the "normal" ground. The modular furniture systems are equipped with raceways that allow for installation of the necessary wiring to individual units. These raceways should be used by the LESSOR for this purpose. A flush mounted faceplate should be used which will recess the voice/data jacks for a cleaner appearance. The location and size of the cut-out should be reviewed with the furniture supplier. The position of jacks is in the raceway. Using Agency will provide separate communication poles for voice and data wiring where required. A construction schedule must be provided to the furniture vendor allowing eight weeks for production time, once color selections are determined. Color selection for the furniture is coordinated with the colors selected for wall and floor coverings. It is the responsibility of the LESSOR to provide elevator use for delivery of the modular systems furniture, if not to be located on ground floors. Where modular furniture is being utilized in private offices, it is the responsibility of the LESSOR to locate the duplex receptacles and voice/data jacks so they are not obstructed by the furniture and must be coordinated with the furniture vendor. When a new lease of space is for the same site as the current lease, it is the LESSOR'S responsibility to disconnect power and communication wiring to modular furniture that is scheduled to be removed/replaced. One additional data communication jack will be installed at the end of each modular unit configuration where printer locations are identified on final floor plans. Modular furniture to be provided by LESSEE. The typical size of the modular furniture to be installed is as follows:

☒ SUPERVISOR	8'x12'	Quantity: 12
☒ CLERICAL/FIELD/CONTRACTOR	6'x8'	Quantity: 115

MULTI-PURPOSE ROOM ☒

This room shall consist of approximately **1105** square feet. This room must be located off of the Client Waiting Area, and may be separated into multiple rooms with an accordion partition, Each separated space shall be constructed as follows, door(s) - with keyed lock and automatic door closures. This room must be wired to meet all voice/data & electrical requirements, every 6' on each perimeter wall and is the responsibility of the LESSOR. Commercial grade exhaust fan(s) vented to the exterior to be installed in such a manner that when the partitions are closed, there is an exhaust fan in each newly created area. Fans to be controlled by on/off switch next to light

switch. (See specifications for all exhaust systems described in the HVAC requirements). One 4' x 8' cork bulletin board. Chair rail perimeter of Multi-Purpose Room installed 36" from floor. Finish shall be natural and approximate color of interior doors.

ACCORDION FOLDING PARTITIONS ☒

The work covered by this section shall include the furnishing of all materials, equipment, and labor necessary for the complete installation of all accordion folding partitions indicated on the drawings or specified herein. Include all accessories and parts necessary to complete this work by an experienced installer, in a professional manner, and in accordance with the manufacturer's installation instructions and warranty requirements. The work includes, but is not limited to, the following: accordion folding partition operated manually. Paired units are required for 10' or larger openings with equal stacking. Soundmaster, Model SM 8 as manufactured by Modernfold or another manufacturer approved by the Department as equal. (See Diagram #11)

CONFERENCE ROOM(s) ☒

This room is located in the staff area and used as a more formal Conference Room. This room shall be constructed as follows, door(s) – with keyed lock and automatic door closures. This room must be wired to meet all voice/data & electrical requirements, every 6' on each perimeter wall and is the responsibility of the LESSOR. Commercial grade exhaust fan(s) vented to the exterior. Chair rail perimeter of Conference Room installed 36" from floor. Finish shall be natural and approximate color of interior doors. The number of rooms to be provided and the size of each is as follows:

☒ MEDIUM Quantity: **1** Size: **510** square feet # participants: **30**

TRAINING ROOM(s) ☒

Each room shall consist of approximately **408** square feet. Door(s) - with keyed lock and automatic door closures. This room must be wired to meet all voice/data & electrical requirements and is the responsibility of the LESSOR. (See section on Voice/Data Requirements). Chair rail the perimeter of the room shall be installed 36" from floor. Finish shall be natural and approximate color of interior doors. Commercial grade exhaust fan vented to the exterior. (See specifications for all exhaust systems described in the HVAC requirements). Furniture to be provided by LESSEE.

STOCK ROOM ☒

This is a supply storage area for the LESSEE. This room shall consist of approximately **150** square feet. This room must be wired to meet all voice/data & electrical requirements and is the responsibility of the LESSOR.

FREE STANDING SHELVING UNITS ☒

Adjustable steel shelving units shall be commercial grade adjustable steel.

- Shelves should be adjustable in height at 1 ½" intervals
- Shelving should be accessible from all four sides to maximum accessibility
- All units should be 84" with depths available at 12", 18", and 24" in order to facilitate the maximum usage of the room size. DPW will specify depth requirements based on stock room configuration.
- Shelving unit should have a base shelf to assure supplies will not be on the floor. Shelves should also have a top shelf with 4 adjustable shelves in between giving a total of 6 surfaces to utilize on each unit.
- Shelving widths should be no less than 36" wide and no more than 60" wide.
- Shelves minimum weighty capacity should be no less than 250 lbs. per shelf.
- Shelving units should be ganged together when set up side by side or back to back.
- Perimeter shelving units are to be anchored to the wall.

LUNCH ROOM ☒

This room shall consist of approximately **528** square feet. Provide and install chair rail around the perimeter of the room 36" from floor. Finish shall be natural and approximate color of interior doors, base cabinets with upper wall-hung cabinets; Formica counter top; **2** microwave oven(s) that are UL/NSF approved, 120 volt, 1000 watts or higher energy star rated and should have a dedicated circuit. (See Commonwealth Standard Building Construction Specifications for all exhaust systems described in the HVAC requirements), **2** full size refrigerator

(energy start rated) with icemaker installed, double deep bowl sink with faucet, a counter top to provide area for a microwave oven(s). Also provide and install liquid soap dispenser, paper towel dispenser, paper cup dispenser and waste receptacle. A cluster of four conventional duplex outlets in the area identified as "Vending Machines". Two Ground Fault Circuit Interrupter (GFCI) duplex receptacles, 125-volt rated, 20-amp, 2-pole, 3-wire grounding, for above counter. LESSOR will maintain all appliances and replace them as required during the initial term and any renewal option periods of the lease.

CONSUMABLES (lunchrooms/kitchenettes)

All lunchroom consumables such as paper towels, liquid hand soap, paper cups, etc will be provided and replenished by the LESSOR at their expense.

COAT RACK(S) ☒

Number to be provided: **12**. These areas shall be 18" deep. A rod shall extend across the entire width as shown on the drawing and be mounted 60" from the floor. This rod must be of sufficient strength to support the coats hung upon it without bending or sagging. A 12" deep (by the width shown on the drawing) shelf shall be mounted 6" above this rod and flush with the rear wall. Locations to be designated by LESSEE.

MAIL HANDLING AREA ☒

Number of staff assigned: **1**. This room shall consist of approximately **150** square feet. This room will be the central location of all incoming and outgoing mail processing and will contain mailroom equipment such as postage machine, scanner and computer equipment. This room must be wired to meet all voice/data & electrical requirements and is the responsibility of the LESSOR. (See Diagram #12)

PROCESSING TABLE ☒

Construct a 5' x 3' table with laminated finish – all surfaces, 30" high to top of table (Subject to CAO approval), storage beneath with cupboard type doors.

MAIL DISTRIBUTION UNIT ☒

This is a free standing unit, to be constructed by the LESSOR, for use in making distribution of mail in one or more locations to various staff members. The basic unit may be installed in several places throughout the office. The total number of bins will be determined by staff in a specific area. The total number of bins in the entire office will be approximately 80% of the total staff. (See Diagram #13)

CENTRAL FILING AREA ☒

This area typically houses centralized files. This area shall consist of approximately **473** square feet. NOTE: GENERAL FLOOR LOAD CAPACITY: All office areas shall have a minimum live load capacity of 50-lbs. per sq. ft. Storage areas shall have a minimum live load capacity of 125-lbs. per square foot.

BULLETIN BOARDS ☒

Install **6** 4' x 8' cork bulletin board(s). Boards must have frames to match interior decor. Locations to be designated by LESSEE.

PRIVATE OFFICES

These rooms must be wired to meet all voice/data & electrical requirements and is the responsibility of the LESSOR.

EXECUTIVE DIRECTOR ☒

Number of rooms required **1**. This room shall consist of approximately **225** square feet each.

MANAGERS ☒

Number of rooms required **3**. This room shall consist of approximately **150** square feet each.

OIG/ AUDITORS AREA ☒

Number of rooms required 1. This room shall consist of 150 square feet to accommodate 1 workstations.

PASSENGER ELEVATORS (if applicable)

For the life of the lease, an elevator maintenance contract must be maintained with a certified elevator contractor. Service response times must be within 24 hours or as outlined in the elevator maintenance contract. All required period testing and/or calibrations, including safety tests, for each hydraulic elevator and electric/cable-type elevator shall be included in the elevator service contract. If elevators exist or are required by code, they are to be modernized to provide automatic operations and to bring equipment into compliance with the Americans with Disabilities Act. The number of elevators identified as available to LESSEE at the time of lease signing must remain available to LESSEE for the life of the lease. At least one elevator must be capable of serving as a freight elevator.

Licenses and permits shall be provided and the required inspections and tests shall be performed. Elevators shall comply with applicable building and elevator codes, The elevators are to be modernized with the following standards as approved by the LESSEE:

- A minimum standard speed of 100 FPM.
- The LESSOR shall provide 24 hours, 7 days per week emergency callback service, with a 3-hour response time on notifications made prior to 2:00 pm local time. Service requests placed after 2:00 pm local time may be responded to on the morning of the following work day.
- Emergency two-way communication system between the elevator and a point outside the hoistway.

The modernization may include complete operational and control systems, software upgrades, new door operators, car operating stations, hall button fixtures, new cab and hoistway doors, complete cab modernization and related repairs. New elevator operations and features may include all aspects of ADA, Firefighter Operation – Phase I and II, independent service, lighted hall and car buttons, traveling lanterns, assign gong, door protective and reopening devices, and raised and Braille characters on elevator car operating stations, hall buttons fixtures, and hoistway entrances. The elevator shall also be tied into the building fire alarm system with elevator recall functions. There must be elevator access to all levels of the building occupied by LESSEE for the life of the lease.

SECTION C. INTERIOR CONSTRUCTION

Refer to the Commonwealth Standard Building Construction Specifications (Attachment B)

SECTION D. FINISHES

FINISH SCHEDULE

SPACE	WALLS	CEILING	FLOOR	BASE	REMARKS
Entry Vestibule	CT*	ACT	Quarry Tile	Quarry Tile	*4' high Vinyl to Ceiling
Waiting/CSR/ Self-Service Areas	V/DW	ACT	VT	VB	
Self-Service Areas	V/DW	ACT	CV	B	
Restrooms	CT*	ACT	CT	CT	*4' high Vinyl to Ceiling
Conference/ Multi-Purpose	V/DW	ACT	CV	BW	With moveable Sound Insulated Partitions
All Private Off.	V/DW	ACT	C	VB	

Workstation Area	V/DW	ACT	C	VB	
Mailroom	V/DW	ACT	C	VB	
Stock Room	P/DW	ACT	VT	VB	
File Room	V/DW	ACT	VT	VB	
Lunchroom	V/DW	ACT	VT	VB	
Lunchroom	V/DW	ACT	VT	VB	
Corridors	V/DW	ACT	C	VB	

SECTION E. ENTRANCES AND EXITS

VESTIBULE

This area shall consist of approximately **150** square feet. Entry vestibule must contain wall-mounted brochure racks to house client informational material if requested by the LESSEE and is the responsibility of the LESSOR.

CANOPY (if needed)

Exterior exit foyers will be required when it will enhance interior floor plan. Large canopy or foyer of permanent type construction must be installed at each entrance and exit, in accordance with the general decor of the building. LESSOR will pay the expenses for the maintenance and installation of the Canopy.

CIGARETTE URN(S)

Provide **2** exterior cigarette urn(s) at entrances and exits.

SECTION F. HVAC – SPECIFICATIONS & REQUIREMENTS

Refer to the Commonwealth Standard Building Construction Specifications (Attachment B)

SECTION G. PLUMBING AND TOILET SPECIFICATIONS

STAFF RESTROOMS

Male and Female restrooms must be constructed in compliance with State and local sanitation requirements. Floor drains are required. Fixtures that must be provided and installed are: metal toilet compartments with doors; metal urinal barriers, all fittings; hardware and fastenings; commercial grade toilet tissue dispensers for each toilet; commercial grade paper towel dispensers, one for each toilet room, commercial grade soap dispensers, self-contained type, one at each lavatory fixture; waste receptacle, one in each toilet room, and one stainless steel edged mirror over each lavatory fixture. A lavatory counter covered with Formica or marlite laminate is to be installed in restrooms where one or more lavatories are to be installed. A privacy barrier or partition must be erected at the entrance to all employees' restrooms to restrict view from the outside. Number of stalls and lavatories to comply with the projected staff occupancy. LESSOR will provide one coin-operated sanitary napkin dispenser and install sanitary napkin disposal units in each ladies toilet stall. LESSOR will furnish napkins and maintain the units. LESSOR will furnish and install a "D" type furniture pull handle at a height between 40" to 44" off the floor to both sides of the handicapped metal toilet compartment doors. Entrance doors to staff restroom require automatic closing devices. Ceramic tile floor or LESSEE-approved substitute and ceramic tile or LESSEE-approved substitute on walls (to the ceiling) must be installed in these rooms to a minimum height of 4'. Any substitutions must be approved prior to construction, in writing, by the Bureau of Real Estate.. Purse shelves, manufactured by the Nik-O-Loc Co., Equipment Division. Indianapolis, Indiana, or equal, to be installed in all toilet booths in the female restrooms. Counter surface recessed soap dispensers, one at each lavatory fixture as manufactured by American Specialties Inc., Model 0332-D or equal to have a 6" chrome finish spout and 3402 (1-liter) soap capacity. Exhaust fans must be provided and installed in ladies' and men's toilet rooms

PUBLIC RESTROOMS ☒

Public toilets for male and female must be provided. A single water closet and lavatory is adequate for the female toilet. Likewise, a single water closet, a urinal, and a lavatory are adequate for the male toilet. These rooms must be constructed and in compliance with State and local sanitation requirements. Floor drains are required. Other fixtures that must be provided and installed are: all fittings, hardware and fastenings; commercial grade toilet tissue dispensers, one for each toilet; commercial grade paper towel dispensers, one for each toilet room; commercial grade soap dispensers, self-contained type, one at each lavatory fixture; waste receptacle, one in each toilet room; stainless steel or equal edged mirror over each individual lavatory fixture in each toilet room. A lavatory counter covered with Formica or marlite laminate is to be installed in restrooms where one or more lavatories are to be installed. Entrance doors will be lockable. LESSOR will furnish and install a "D" type furniture pull handle at a height between 40" to 44" off the floor to both sides of the handicapped metal toilet compartment doors. Coin-operated sanitary napkin dispenser not required in client restroom, however, a sanitary napkin disposal receptacle is required in the client female restroom. Ceramic tile floor or LESSEE-approved substitute and ceramic tile or LESSEE-approved substitute on walls (to the ceiling) must be installed in these rooms to a minimum height of 4'. Any substitutions must be approved prior to construction, In writing, by the Bureau of Real Estate..Purse shelves, manufactured by the Bradley Corporation, Menomonee Falls, Wisconsin, or equal, are to be installed in all toilet booths in the female restrooms. Counter surface recessed soap dispensers, one at each lavatory fixture as manufactured by American Specialties Inc., Model 0332-D or equal to have a 6" chrome finish spout and 3402 (1-liter) soap capacity. The LESSOR is responsible for providing and installing a baby changing stations in male and female public restrooms.

ELECTRIC WATER COOLERS ☒

Electric water coolers, Cordley and Hayes, Halsey Taylor, Westinghouse, or approved equal, with cup dispensers, must be installed with cold water piping and sanitary drains. A minimum of two (2) are required; and at least one (1) per floor will be required in multi-floor locations. One water cooler on each occupied floor must comply with Act 235 requirements. LESSOR must provide and replenish cups for the coolers. A supply of cups must be made available to the LESSEE.

SECTION H. ELECTRICAL SPECIFICATIONS

Refer to the Commonwealth Standard Building Construction Specifications (Attachment B)

SECTION I. SPECIAL SYSTEMS

SECURITY SYSTEM ☒

Provide a security system to alarm audibly within the building and annunciate at a central remote station upon unauthorized intrusion into the leased space during specified hours of the week. Provide a seven-day changeable program for this system. Provide, install, and maintain a dedicated voice analog/digital telephone line. It will be the responsibility of the LESSOR to assume the ongoing cost of monitoring and maintaining the system during the term of the lease, as well as to respond to alarms when they occur. LESSOR to provide ongoing training, as requested by the Using Agency, throughout the life of the Lease.

KEYLESS ENTRY DOOR ☒

Push button and/or keyless lock entry are required on any interior doors between client waiting area and staff work area as identified on floor plan. At least one door must be equipped with a keyless entry system for employee building access.

NOTE: If proposed space is on two levels, then an additional one or two security locks may be required.

SECURITY PUSH BUTTON LOCKS ☒

Manufacturers, for the purpose of establishing a standard of quality for both the product and installation, the below listed model is to be installed. Installation of equivalent models, provided by other manufacturers, requires prior approval of the Using Agency.

Model: ILCO Unican 1000 Series, lever type

ELECTRONIC NUMBERING SYSTEM ☒

An electronic numbering system will be supplied to provide traffic management of clients that require face-to-face consultation with a CSR. Each system will have a ticket printer that includes a button for clients to press to get the next numbered ticket. Each numbered ticket will include the current date and time. The ticket printer will have the capability to add additional buttons for multiple services and multiple number sequences. Each printer will also have the capability of printing a company logo. The printer will be located at the Greeter Station.

Each waiting area will have a 3-digit LED display with 5" high digits that will show the next number being called. Depending on the size of the office, 2 displays may be required.

Each CSR will have a 3-digit display with 2-1/3" high digits mounted above their station.

Each CSR will have a button that is pressed to advance to the next number. That number will appear on the waiting room display(s) as well as the available CSR display.

One CSR station will have 3 additional buttons to control the system as needed. These buttons will be labeled "Next" "Previous" and "Reset".

Each system will have reporting capabilities as follows:

- Wait times by service type (when using more than 1 numbering sequence)
- Wait times by hour of the day
- Number of customers served
- Number of customers by service type (when using more than 1 numbering sequence)
- Number of customers served per window
- Daily, weekly & monthly reports

INTERCOM PAGING SYSTEM ☒

The LESSOR will provide and install a paging system consisting of speaker assemblies (speakers, transformers, grills, etc.), speaker back boxes, bridge supports, volume controls, equipment rack and any other accessory required to provide a fully operational system. The amplifier will be of sufficient wattage to ensure that it can adequately power the number of installed speakers with sufficient space wattage to handle a 25 percent increase in the number of speakers. Most speakers will require one-watt of power for satisfactory operation. The paging intercom must include an adequate number of speakers throughout the building to ensure coverage to all areas designated by the facility director. The system must be equipped to provide a maximum of four zones and an all call and must have the capability of being activated from any designated telephone. Paging speakers located in the conference room and multi-purpose rooms must have volume controls. All wiring will be 18-gauge stranded, twisted, shielded pair. Steel or aluminum wire molding will be used wherever the cable cannot be concealed.

NOTE: The total number of speakers required should be based on providing one speaker for every 300 square feet of area provided under this project. Maintenance and repair of this paging system will be the responsibility of the LESSOR.

SECTION J. MISCELLANEOUS SPECIFICATIONS

FLOOR DIRECTORY (MULTI-TENANT BUILDINGS) ☒

Provisions must be made for the Commonwealth Agencies program functions to be included in the floor directory when located in a building with multiple floors. All signage related to Commonwealth Agency tenants located in the building must be approved by the Department of General Services, Bureau of Real Estate.

BUILDING IDENTIFICATION ☒

Specifications to be provided prior to commencement of construction. (See Diagram #14)

In the event that building signage needs to be repaired or replaced, the LESSOR is responsible to contact the DPW, DFPM Leasing Office to ensure compliance with the most current Governor's Office branding specifications for DPW building signage.

EMERGENCY GENERATOR DOCKING STATION AND TEMPORARY GENERATOR ☒

An emergency generator docking station and designated location for a portable emergency generator shall be provided on the exterior of the building. The docking station shall contain male color coded camlock connections with theft prevention for the input of an emergency generator for proper phase rotation. The docking station shall include a ground fault type receptacle for the generator battery charger, a ground fault receptacle for the generator water jacket heater, and generator connecting instructions. A manual transfer switch shall be provided to switch between generator and utility power. Upon loss of utility power for periods extending more than one business day, provide a temporary diesel generator, cables, and connections to the generator docking station. The docking station shall be sized to connect to a generator that will: 1) power at least 50% of the building's interior lighting; 2) power all workstations and servers; 3) power the UPS system and the air conditioning in the LAN/tech room; and 5) power heating for the building during the heating season.

PEST CONTROL ☒

DESCRIPTION OF SERVICES

Pest Control services will include labor, materials, services, skills, supervision, and necessary tools and equipment to insure that facilities will be free of pests and/or termites. Integrated Pest Management (IPM) methods should be used to the extent possible to remove and exterminate rodents, insects, and other pests.

PESTS INCLUDED FOR PREVENTION AND/OR ELIMINATION

General Pests: Including but not limited to, cockroaches, ants, spiders, silverfish, centipedes, millipedes, earwigs, flies, fleas, bed bugs, stored products pests, occasional invaders and other similar insects, as well as bees, wasps, hornets and yellow jackets in areas up to 12 feet high. 2) Rodents: Including but not limited to, mice, rats and perimeter treatments of herbaceous growth around various area(s) or building(s) to be serviced, which could harbor rodents. 3) Termites and other wood destroying organisms.

PESTICIDE APPLICATION

Pest Control providers should possess and maintain a valid Pesticide Application Business License Certificate and the Commercial Pesticide Applicator Certificates for every Contractor Employee who will be performing on-site services issued by the Pennsylvania Department of Agriculture (PDA). These licenses and certifications must be maintained throughout the life of the lease. No pesticide product should be stored on the property. No pesticide products should be applied that have not been included in the Pest Control Plan. Non-pesticide methods of control should be used wherever possible. Only products permissible under current State and Federal Regulations may be used and those used only in strict accordance with precautions, directions and recommendations shown on the label of the product. Pesticides being used shall be registered with EPA and PA Department of Agriculture. Provide treatment using only pesticides that comply with the provisions of the Federal Insecticide, Fungicide and Rodenticide Act of 1972 and the Pennsylvania Pesticide Control Act of 1973 and the regulations issued there under. Pesticides applied to the air should never be used for routine treatment inside facilities. Pesticides should be applied only as containerized or crack and crevice treatments in which the applied treatment not readily visible. Any excess pesticide applied should be readily cleaned according to manufacture specifications. Insecticides should be applied only as baits formulated as solids, pastes, or gels. Spray or dust formulations should be selected only as a last resort or when solids, pastes, or gels are not practical. Routine pest control services should not adversely affect occupant health or productivity during normal working hours of operation in the buildings.

MANNER AND TIME TO CONDUCT SERVICES

When it is necessary to perform work outside of the regularly scheduled hours set forth in the Pest Control Plan, the LESSOR shall notify the LESSEE at least one (1) day in advance. Prior to initiation of service, the LESSOR shall submit a written Integrated Pest Management Pest Control Plan to the requesting agency. The LESSOR's representative shall be on site to initiate service within an agreed upon number of working days following notification by the LESSEE. The Pest Control Plan shall consist of proposed methods for control, including labels and Material Safety Data Sheets (MSDS) for all pesticides to be used, a list of types of tamper-resistant rodent

bait boxes, insect and rodent trapping devices, pest monitoring devices, and any other control devices or equipment; a service schedule for inspection, monitoring, and/or pesticide application for the various area(s) to be serviced; a copy of the Commercial Pesticide Applicator and/or Registered Technician Certificate for every Contractor's representative who will be performing on-site service. The LESSOR shall receive concurrence of the LESSEE prior to implementing any subsequent changes to the approved Pest Control Plan including additions or replacements to the pesticide list.

STATE AGENCY RESPONSIBILITIES

Whenever conditions conducive to the breeding and harborage of pests, covered by this contract are reported in writing by the LESSOR to the CAO office of record and the DPW, DFPM, Leasing Office, the LESSEE shall take the necessary steps to correct such conditions, if possible. If corrective action is not taken within a mutually reasonable time, the LESSOR should notify DGS, BRE. LESSEE will be expected to extend all necessary cooperation to LESSOR to insure effective pest control results.

RECORD KEEPING

The LESSOR shall be responsible for maintaining a pest control logbook or file for each building or site. These records shall be kept on the property being serviced, as well as with the LESSOR and be kept up-to-date. Each logbook or file shall contain a copy of the Pest Control Plan for the building or site, the service schedule for the building, the Pest Control Service Record(s) and Pest Inspection Report(s). This includes all the information on pesticide applications required by the Pesticides Rules and Regulations 7 PA Code CH. 128 as amended October 12, 2001. Logbook will also be used for each site to report pest sightings by LESSEE to the LESSOR.

SPECIAL REQUESTS AND EMERGENCY SERVICE(S)

On occasion, LESSEE may request the LESSOR to perform corrective, special or emergency service(s) that are beyond routine service requests. The LESSOR shall respond to these exceptional circumstances, which normally involves a threat to health or a major disruption of normal work activities and complete the necessary work within four (4) hours after receipt of the request, with the exception of the requirements contained in 7 PA Code CH. 128, Subchapters C & F, as amended October 12, 2001. A twenty-four hour telephone number(s) shall be provided so LESSEE can contact the LESSOR in the event of suspected or actual emergency involving pest infestation.

SERVICE MAINTENANCE CONTRACTS

The LESSOR shall provide and operate all building equipment and systems in accordance with applicable technical publications, manuals, and standard procedures. Mains, lines, and meters for utilities, shall be provided by the LESSOR. Exposed ducts, piping and conduits are not permitted in office space. Maintenance service contracts will be developed with certified service providers, and maintained for the life of the lease, in the following areas: roof, HVAC systems, and elevators. Service response times must be within 24 hours. LESSOR shall submit copies of the maintenance contracts to DGS, BRE.

SECTION K. VOICE/DATA REQUIREMENTS

The LESSOR will be responsible for providing all voice and data requirements included in this specification. The LESSOR will provide and install the entrance conduit which brings the voice and data services into the building and any required conduit and feeder cable within the building to bring services to the Telecommunications Equipment Room. Feeder cable used within the building to extend demarcation point services will be connected to 110-type 5 pair (Using C5 clips) connecting blocks on a wallboard using 25, 50, or 100 pair Category 3 riser cabling. The number of pairs to be extended to the Telecommunications Equipment Room must be coordinated with the DPW Telecommunications Unit before installation. Exclusively, DPW will use the Telecommunications Equipment Room. The Service Provider under contract with the Commonwealth will be responsible for installing the cable and/or fiber facilities from the telephone company's central office to the facility where they will terminate the cable and/or fiber at a demarcation point. From this demarcation point, the LESSOR and/or their designated subcontractor will be responsible for providing and installing all voice and data facilities and material within the building using American National Standards Institute (ANSI), Telecommunications Industry Association (TIA), and Electronic Industries Alliance (EIA) approved commercial building standards, except for the telephone system and data equipment. This includes, but is not limited to the following:

- Telecommunications Equipment Room
- Main Cross-Connect (MC), also known as Main Distribution Frame (MDF)
- Modular patch panel equipment with associated patch cords
- Voice and data wiring and hardware, including cross-connecting blocks
- Power poles and/or wire moldings where required
- Necessary wiring and telephone in each elevator as required

GENERAL REQUIREMENTS

The current version, unless otherwise noted, of ANSI/TIA/EIA-568 Commercial Building Wiring Standards shall be the required installation standards of this specification and shall be used as the minimum characteristics for Category 5e(350M) cable installation.

All wiring or cable for this specification will be classified as "Communication Circuits" (voice and data) and will be installed and maintained under the strict guidance of the National Electric Code (NEC) Provision as found in Article 800-Communications Circuits.

All cable or wiring referred to by this specification MUST be ANSI/TIA/EIA-568 compliant for category 5e(350M) cable. All four pairs of every station cable, both voice and data, shall be terminated (wired for T568B specifications) providing continuity of all pairs from every workstation back to the appropriate MC in the Telecommunications Equipment Room.

All hardware MUST be ANSI/TIA/EIA-568 compliant for Category 5e(350M) cable installation. Termination at the MC shall be onto category 5e(350M) compliant eight pin (wired for T568B specifications) patch panel equipment.

ANSI/TIA/EIA – 607 Commercial Building Grounding and Bonding Requirements for Telecommunications shall be followed.

Required electrical outlets, voice, and data locations are not presented on the typical plans; however, all electrical outlets, voice, and data jack locations will be identified on the drawings provided by the Department of Public Welfare.

All alarm systems are the responsibility of the LESSOR which includes the telephone numbers to support the system. The LESSOR will purchase their own telephone service from the local provider.

NOTE: Placement of electrical, voice/data outlets must be located so as not to interfere with modular furniture placement. A vertical pathway or power pole is used to provide a pathway from the ceiling or horizontal pathway area when the outlet location is not adjacent to a wall. Voice and data will be run through separate power poles from the poles providing electrical power so that the number of poles required to meet ANSI/TIA/EIA-569 standards for the job will be reduced for the installer. Pathway percent fill is calculated by dividing the summation of the cross-sectional area of all cables by the most restricted cross-sectional area of the pathway. For planning furniture pathways, the maximum pathway fill shall be 40%. A maximum of 60% pathway fill is allowed to accommodate unplanned additions after initial installation.

TELECOMMUNICATIONS EQUIPMENT ROOM

The Telecommunications Equipment Rooms shall be as centrally located as possible on each floor. This requirement is critical to ensure that no voice or data location exceeds the 100-meter rule of the ANSI/TIA/EIA-568 standards. The door will be equipped with a lockable passage set.

NOTE: The Telecommunications Equipment Room will be used exclusively for Department of Public Welfare voice and data communications. No other agency and/or tenants may use or have access to the Telecommunications Equipment Room. With the exception of the normal service power requirements identified herein, no electric/power equipment or panels nor mechanical equipment, including Building HVAC units, will be housed in this room.

Minimum room size is 9' x 12'. See sizing room requirements below

Maximum temperature is 72°F. Independent air conditioning shall be installed for the telecommunications room so that a maximum temperature of 72°F is maintained year-round for the installed electronic equipment.

Up to eleven (11) duplex dedicated/isolated A/C power outlets, four (4) duplex or two (2) quad dedicated/isolated A/C power outlets must be installed in the data rack and one duplex outlet with Leviton 4720-C twist lock as designated by the DPW Telecommunications Unit.

Two conventional duplex outlets on a common circuit.

Up to two (2) duplex voice jacks and up to four (4) duplex data jacks as designated by the DPW Telecommunications Unit.

The door will be equipped with a lockable passage set. No other tenants may use or have access to this room.

There shall be no water or drain pipes, electric/power equipment or panels, nor mechanical equipment including Building HVAC units located in these rooms.

TELECOMMUNICATIONS EQUIPMENT ROOM SIZE

Buildings OVER 10,000 square feet:

- Single floor buildings: Room Size 13 feet x 15 feet.
- Buildings with more than one floor: Main equipment room size 13 feet x 15 feet and a similar size room on each floor. Room locations for multiple floors will be stacked on top of each other.
- The lighting requirements and general architectural finishes shall be the same as the general office areas. Due to the heat generation of the electronic equipment, it is typical to have a year-round cooling load for the Telecommunication Room. The Telecommunication Room shall have a temperature-controlled cooling system completely independent from the building HVAC systems. Typically, these independent cooling systems are mini-split DX style with integral temperature controls, wall-mounted evaporator units with outdoor condensing units. The independent cooling system shall maintain a maximum space temperature set point of 72°F year-round.
- The LESSOR will install tile on the floor of each Telecommunications Equipment Room. No carpeting, including anti-static carpeting, shall be used.
- The LESSOR will ensure that a vertical chase (open area for cable runs between floors) is installed or coring with sleeves is installed between the main Telecommunications Equipment Room and any Intermediate Cross-Connect(ICC) or additional Telecommunications Equipment Rooms.
- Entrance door shall be 36 inches wide and key lockable.
- Service power shall be 120 volt, 60 Hz, 20 Amp.
- Up to eleven (11) duplex dedicated/isolated A/C power outlets, four (4) duplex or two (2) quad dedicated/isolated A/C power outlets must be installed in the data rack and one (1) duplex outlet with Leviton 4720-C twist lock as designated by the DPW Telecommunications Unit.
- Four (4) duplex conventional A/C power outlets on a common circuit as designated by the DPW Telecommunications Unit.
- Two (2) duplex voice jacks and four (4) duplex data jacks as designated by the DPW Telecommunications Unit.
- There shall be no water or drain pipes located in these rooms.

MAIN CROSS CONNECTION (MC)

The MC will be located in the Telecommunications Equipment Room. The LESSOR will provide and install 110-type connecting blocks and will also provide and install eight point modular jack patch panel equipment. All equipment must be in compliance with ANSI/TIA/EIA-568 for Category 5e (350M) hardware. Line Side patch panels will be connected to the wallboard using 110-type, 4 pair, (C4) connecting blocks mounted on the wallboard using 25 pair Category 5e (350M) riser cable runs. All Line Side, Voice, and Data Station Patch Panel jacks will have all four-pair punched down to the T568B specifications.

The patch panel equipment shall be no larger than standard size 24-port, and no high density space saver patch panels will be used without prior approval from the DPW Telecommunications Unit. The patch panel equipment

will be of sufficient size to accommodate all existing voice/data requirements and at least 15 percent spare patch panel ports for growth. The LESSOR must provide and install all the patch panel hardware required to make the system operational, including all voice and data patch cords and the designated wire management panels used to dress the patch cords between the patch panels in a neat and orderly fashion. Wire management will consist of Panduit Slotted Duct style Horizontal and Vertical cable Management panels. Also included will be four pair Category 5e (350M) compliant patch cords in various lengths to accommodate the total number of Voice and Data jacks installed plus 15 percent spare cords for growth. The patch cords will be sized to ensure a neat and orderly appearance. Refer to the Telecommunications Equipment Parts List for the information you will need to meet the mandatory installation requirements. Any deviation from this list must be approved by the DPW Telecommunications Unit in writing detailing the changes and reason for substitution. Any substitutions proposed must meet all of the same specifications and/or requirements as the original item.

TELECOMMUNICATIONS EQUIPMENT PARTS LIST

<u>Description</u>	<u>Vendor</u>	<u>Part Number</u>	Substitutable
Mini-Com TX5e Jack Module	Panduit	CJ5E88TIW	
Mini-Com Blank Module	Panduit	CMBIW-X	
Mini-Com Ultimate ID Classic Series Faceplates	Panduit	UICFP4IW	
19" Standard Rack	Panduit	CMR19X84	Yes
DP5e Patch Panel 24 port	Panduit	DP245E88110U	Yes
Standard Vertical Slotted Duct (Front and Rear) 4wX5dX83h	Panduit	WMPV45	
Standard Vertical Slotted Duct (Front only) 4xX5dX83h	Panduit	WMPVF45	
Standard Horizontal Cable Managers 19" Manager (Front only)	Panduit	WMPHF2	

VOICE REQUIREMENTS

On one wall designated by the DPW Telecommunications Unit, one 4 feet X 8 feet sheet or two 4 feet x 4 feet sheets of three-quarter inch plywood will be attached for mounting the MC in the Telecommunications Equipment Room (if there are additional floors that have a Telecommunications Equipment Room, they are to have the same plywood installation as the MC) for voice. The plywood will be attached in such a way that the top of the highest patch panels shall not be higher than six feet two inches and the bottom of the lowest patch panel shall be no lower than two feet from the floor.

The voice MC will consist of Category 5e (350M) compliant 110-type, 4 pair (C4) connector blocks, mounted on the wallboard, and then terminated to the Line Side patch panels that are Category 5e (350M) compliant eight point modular jack patch panel equipment (wired for T568B specifications) using 25 pair Category 5e (350M) cable runs. Voice Station patch panels that are Category 5e (350M) compliant, eight point modular jack patch panel equipment (wired for T568B specifications) using 4 pair Category 5e (350M) cable runs will terminate to a Category 5e (350M) compliant, eight pin (wired for T568B specifications) RJ-45 end-user interface jack. All four pairs will be terminated for each jack on the Line Side patch panel to the 110-type, 4 pair (C4) connector blocks. The maximum size of the patch panel equipment will be 24 ports. No high-density space saver patch panels will be used without prior approval from the DPW Telecommunications Unit.

Two (2) duplex dedicated/isolated A/C power outlets shall be located on the wall directly below each piece of plywood. Two (2) additional duplex dedicated/isolated A/C power outlets, one (1) with Leviton 4720-C twists locks, will be installed in close proximity to be used by the telephone company.

All Voice patch panels will be installed in 19" X 84" floor mounted racks. Any deviation from this requirement must be approved in writing by the DPW Telecommunications Unit. The top of the highest patch panels shall not be higher than six feet two inches and the bottom of the lowest patch panel shall be no lower than two feet from the floor.

All metal floor-mounted voice frames will be equipped with a #6 AWG solid copper ground wire attached to an approved electrical ground.

The first set of Voice patch panel equipment at the top will be designated as the Line Side patch panel. Each available port will be connected to 110-type blocks with all four pairs terminated. From these cross-connecting blocks, all existing telephone lines will be cross connected to the telephone company demarcation point.

The second set of Voice patch panel equipment will be designated as the Station side patch panel and will have all four pairs terminated to the appropriate Station jacks as required.

A modular voice jack will be installed in the Telecommunications Equipment Room for use with the intercom paging systems.

DATA REQUIREMENTS

The Data MC will consist of Data Station patch panels that are Category 5e (350M) compliant eight point modular jack patch panel equipment (wired for T568B specifications) using 4 pair Category 5e (350) cable runs will terminate to a Category 5e (350M) compliant, eight pin (wired for T568B specifications) RJ-45 end-user interface jack. The maximum size of the patch panel equipment will be 24 ports. No high-density space saver patch panels will be used without prior approval from the DPW Telecommunications Unit.

All Data patch panels will be installed in 19" X 84" floor mounted racks and located next to the floor mounted Voice rack. Any deviation from this requirement must be approved in writing from DPW Telecommunications Unit. The top of the highest patch panels shall not be higher than six feet two inches and the bottom of the lowest patch panel shall be no lower than two feet from the floor.

Mounted on the extreme lower portion of the data frame will be four (4) duplex or two (2) quad dedicated/isolated A/C power outlets each having a dedicated circuit with an isolated ground. The outlets should be arranged to accommodate transformer connections (which frequently are larger than a standard plug) without blocking access to other outlets. This metal floor-mounted data frame will be equipped with a #6 AWG solid copper ground wire attached to an approved water pipe ground.

Three (3) duplex dedicated isolated A/C power outlets shall be located on the wall adjacent to the floor mounted frame for data.

A duplex voice jack will be installed in close proximity to the data frame to support a dial-up modem for diagnostic trouble shooting.

STATION WIRING

All cable for both voice and data will be four pair, Category 5e (350) compliant, Type CM communications cable, 24-AWG, solid conductor, unshielded twisted pair, meeting the electrical and corresponding distance requirements of ANSI/TIA/EIA-568 Commercial Building Wiring Standard.

All station wiring for both voice and data will be home run, no intermediate cut downs or splices, to the appropriate telecommunication room and terminated directly onto Category 5e (350) compliant patch panel equipment. All four pairs must be physically terminated at the Category 5e (350) compliant eight pin modular telecommunication outlet and at the appropriate patch panel equipment port.

All cable shall be concealed either above a suspended ceiling, in conduit, in wire mold, or behind partitions. A maintenance loop of 6 feet to 10 feet is required to provide enough slack at the MC to accommodate any future movement of the terminating wires on their respective voice or data patch panel terminations.

CONDUITS, POWER POLES AND PLENUM RUNS

All installed pathways will follow the ANSI/TIA/EIA-569 standard.

All wiring not in conduits and run in air handling plenums will have Type CMP communication plenum cable, low-smoke, heat resistant Haler type insulation.

All conduits will be metal (EMT) type conduit or raceways.

All access holes through floors, walls, etc. that must be drilled for the installation of voice and data facilities must be provided by the LESSOR. These access holes must be equipped with a sleeve and bushings at both ends and must be properly fire-stopped at both ends.

Wire mold, conduits, or power poles will be required to those voice and data locations where the wiring cannot be concealed or readily fished through walls, etc. All exposed voice/data cable attached to office walls, ceilings, or floors will be concealed using approved surface raceway molding. Lesser will separate the Voice and Data wiring from the electrical power and dedicate a pole for each to the modular furniture. For planning furniture pathways, the maximum pathway fill shall be 40 percent. A maximum of 60 percent pathway that is not filled is allowed to accommodate unplanned additions after initial installation.

In multi-channel raceways, dividers separating compartments shall be bonded to ground in accordance with ANSI/TIA/EIA-607.

Metal raceway bases, covers and dividers shall be bonded and grounded in accordance to applicable codes and ANSI/TIA/EIA-607.

JACKS

Both voice and data wiring will be terminated on Category 5e (350) compliant duplex voice/data jacks, or single voice or data jacks, as required, at the workstation location (wired for T568B specifications). All station jacks must meet or exceed ANSI/TIA/EIA-568 standards for Unshielded Twisted Pair Connecting Hardware for Category 5e (350) cable.

Duplex voice/data connecting blocks will have two eight-conductor (wired for T568B specifications) modular jacks labeled by the manufacturer as "V" for voice and "D" for data, with a single face plate. All end-user interface boxes must be secured with mounting screws. No double-sided tape will be permitted. The inserts of the jacks will be color-coded - blue inserts for voice and orange inserts for data. Any deviations must be approved by the DPW Telecommunications Unit in writing detailing the changes and reason for substitution. Any substitutions proposed must meet all of the same specifications and/or requirements as the original item. All labeling will use permanent mechanically/electronically made markings.

CODING, RECORDS, AND TRAINING

All voice and data eight pin modular locations at the End-user Station jack and at the Patch Panel equipment will be labeled with permanent mechanically/electronically made markings by the LESSOR for identification by Department staff. The numbering scheme should be kept constant and consecutive (V1 / D1...V288 / D288) throughout the entire site. Patch Panels and End-user Station jacks must be labeled with permanent mechanically/electronically made markings.

A cable record of all pairs at the MC will be prepared by the LESSOR. One copy of this record must be submitted to the DPW Telecommunications Unit prior to final acceptance of the facility.

The LESSOR shall provide training in the proper use of the cable records and the patch panel equipment. The method and depth of the training will be sufficient to train the user to correct deficiencies as rapidly as possible and also allow the user to readily make voice/data station location changes via the patch cords.

TESTING

The LESSOR and/or his designated subcontractor will be responsible for performing testing of all voice and data wiring and hardware to assure compliance with equipment specifications. All voice and data wiring and hardware must meet or exceed all the specifications of ANSI/TIA/EIA-568 for Category 5e (350) cable installation. The LESSOR and/or his designated subcontractor must provide the DPW Telecommunications Unit with a complete copy of all test results prior to final acceptance of the facility.

At a minimum, the test results for each jack, voice and data, must contain:

- Jack Number
- Cable Length
- Wire Map
- Attenuation
- NEXT (Near End Cross Talk)
- Cable Impedance

TERMINATIONS AND WIRING DIAGRAM

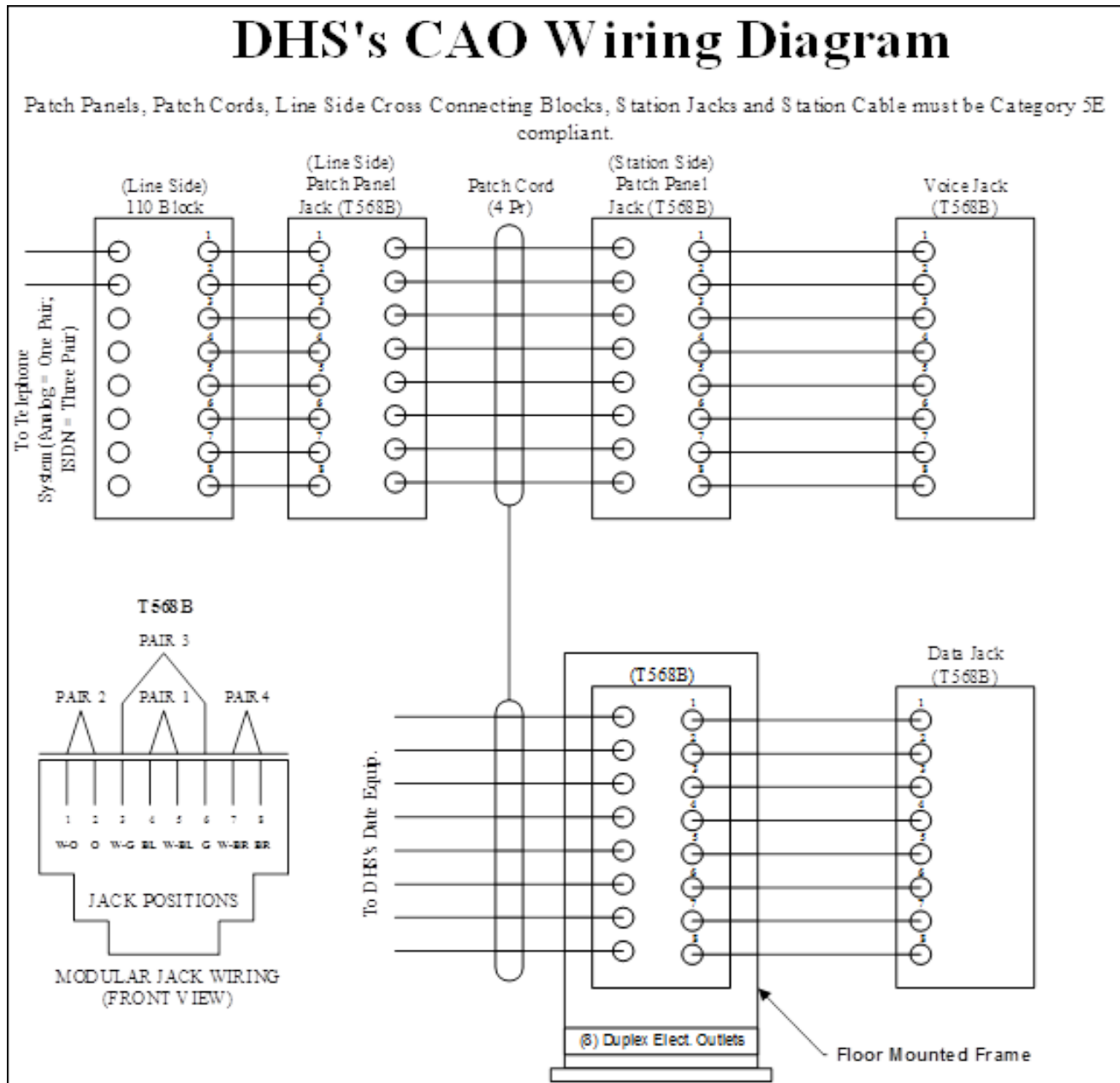

The eight pin modular connectors for voice\data and the patch panel modular jacks shall be terminated to T568B specifications as follows:

DATA AND VOICE RACK LAYOUT

Small Office Layout

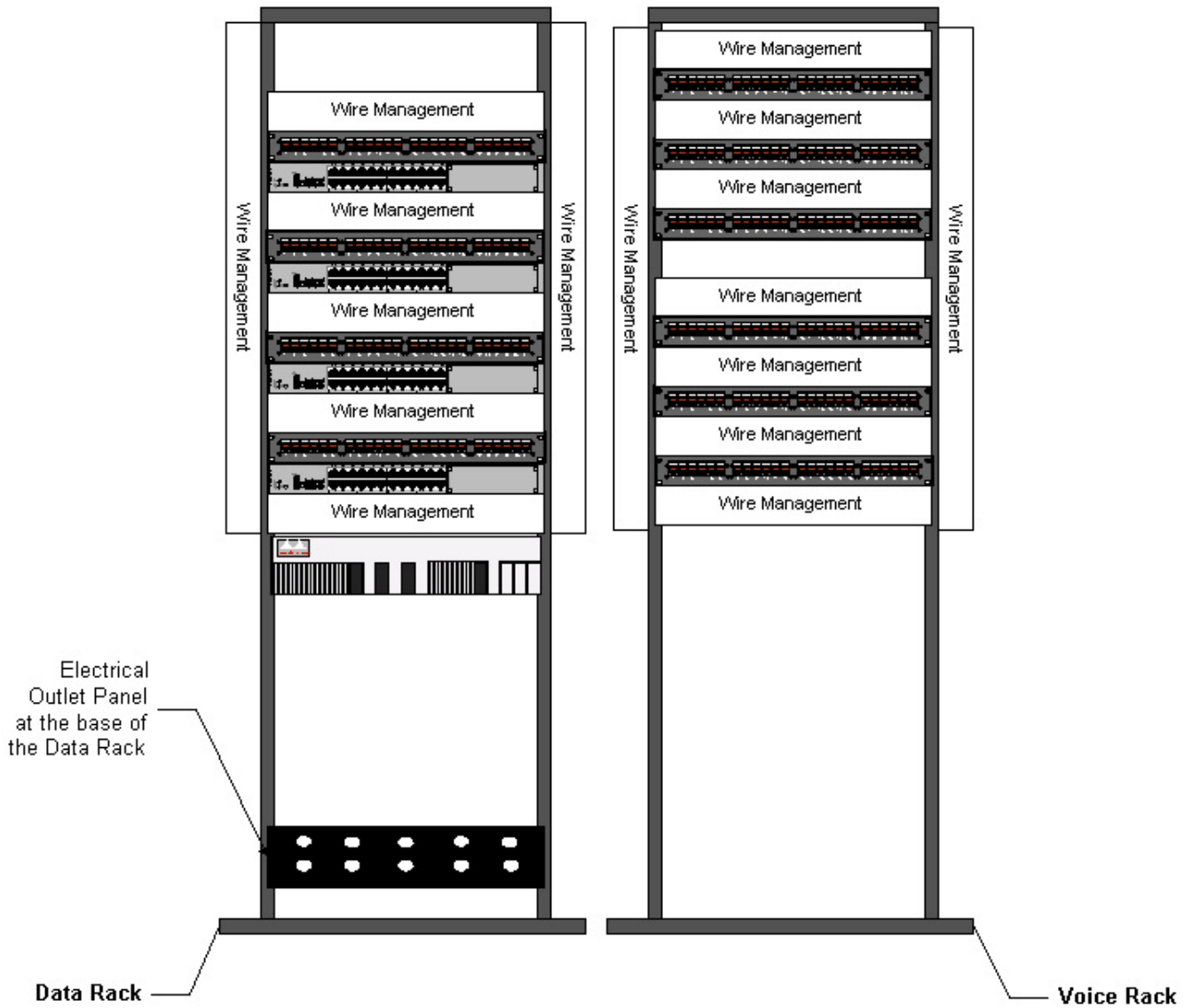

Typical Data and Voice Rack Layout

NOTE: Electrical outlet panel will have five isolate ground duplex electrical outlets.

Large Office Layout

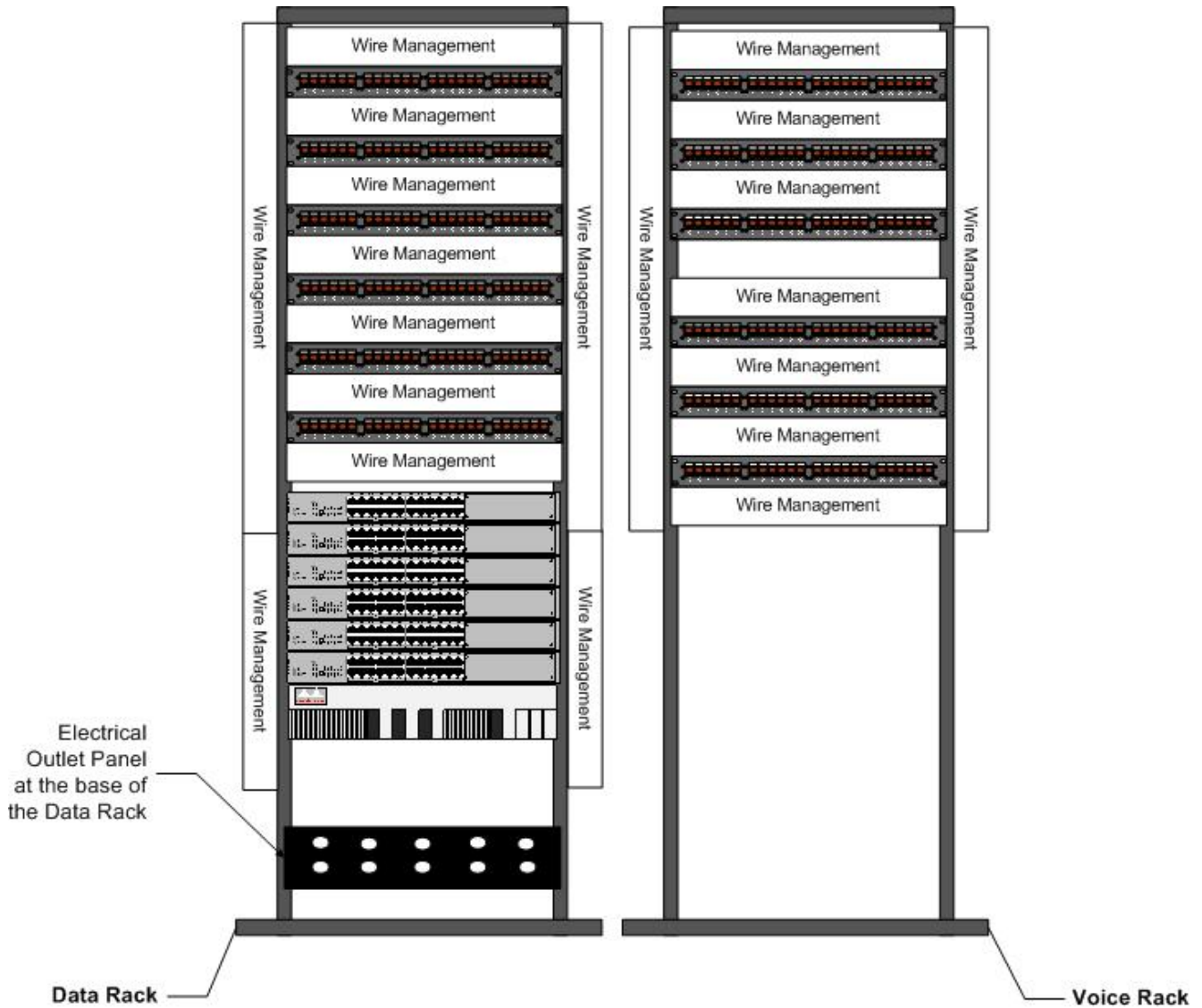

Typical Data and Voice Rack Layout for Large Office Using Gig Switches

TELECOMMUNICATIONS ROOM LAYOUT

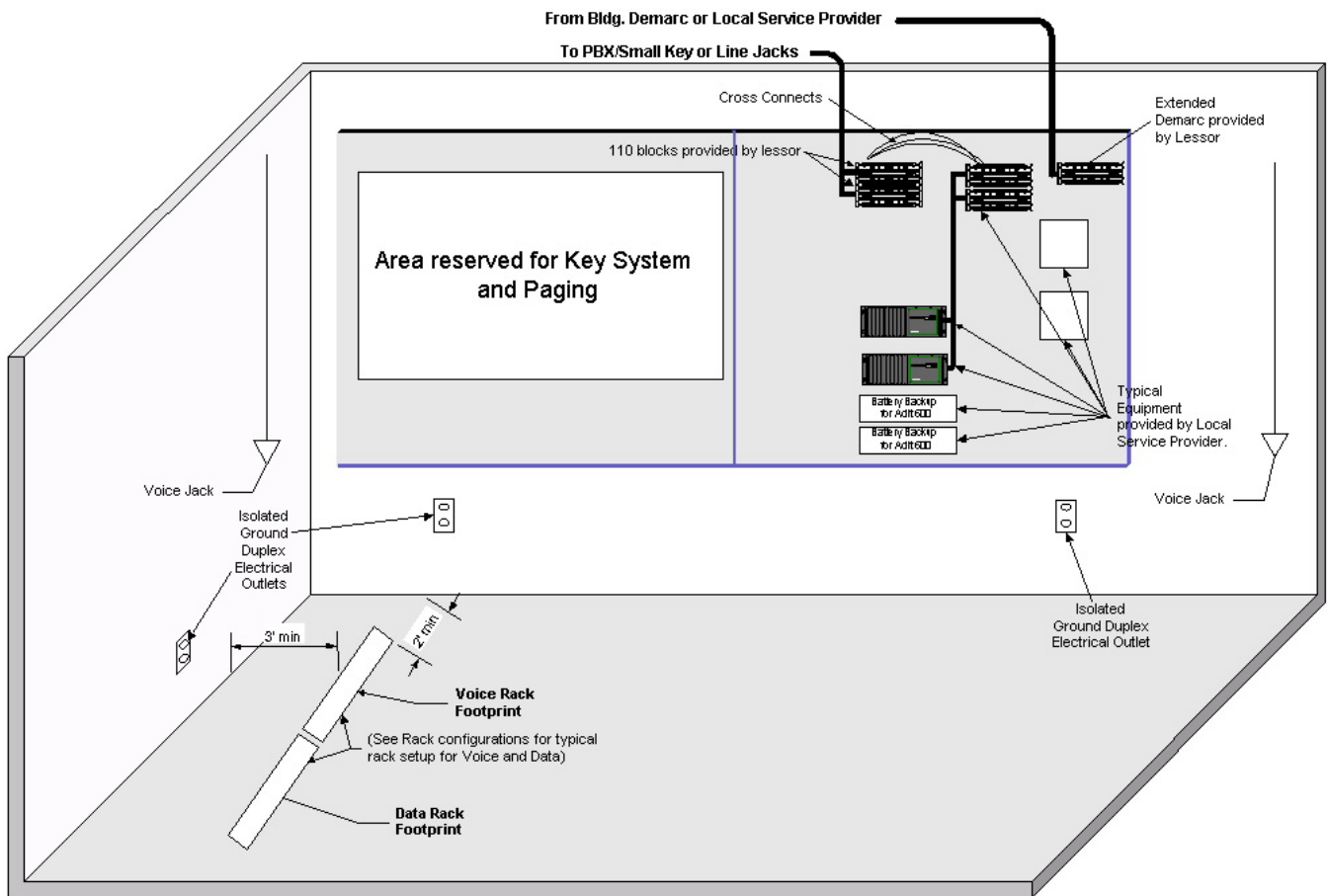

Typical Telecommunications Room Layout

NOTE: On wall left of the voice and data rack will have two isolated ground duplex electrical outlets and one Leviton Twist Lock 4720C outlet. Also on this wall will be five data jacks.

PATCH PANEL REQUIREMENTS

Standard size hinged 24-port panel.

A minimum of 15% spare patch panel ports will be provided for growth. Panduit wire management panels will be used to dress all cabling front and in back of the rack. Panduit Slotted Duct Style Wire Management Panels will be used between each 24-port unit as well as on the sides.

Panels will be labeled with permanent mechanically/electronically made marking.

Voice Line Side patch panels will be terminated to the 110-type connector blocks will all four pairs terminated for each port.

Voice patch panels will be mounted within a floor mounted 19" x 84" rack.

Data patch panels will be mounted within a floor mounted 19" x 84" rack.

Spare patch cords will be supplied for voice and data panels. A minimum of 15%, the number of each spare cord length (3', 5', and 7') will reflect percentages of those used during the installation (80% of the patch cords should be 3' in length).

VOICE AND DATA CABLE T56B

All cable will be four pair, Category 5E compliant. Voice and Data cable sheathing will be of a different color. Any modular furniture that requires power poles will have separate poles for Voice/Data and Power.

VOICE AND DATA JACKS

Jacks will be labeled with permanent mechanically/electronically made markings. Single and/or duplex jacks will be labeled "voice" and/or "data", and include the port number, on a single faceplate. The inserts of the jacks will be color-coded: *blue* for voice and *orange* for data.

INTERCOM PAGING SYSTEM

The LESSOR will provide and install a paging system consisting of speaker assemblies (speakers, transformers, grills, etc.), speaker back boxes, bridge supports, volume controls, equipment rack and any other accessory required to provide a fully operational system. The amplifier will be of sufficient wattage to ensure that it can adequately power the number of installed speakers with sufficient space wattage to handle a 25 percent increase in the number of speakers. Most speakers will require one-watt of power for satisfactory operation.

The paging intercom must include an adequate number of speakers throughout the building to ensure coverage to all areas designated by the facility director. The system must be equipped to provide a maximum of four zones and an all call and must have the capability of being activated from any designated telephone. Paging speakers located in the conference room and multi-purpose rooms must have volume controls.

All wiring will be 18-gauge stranded, twisted, shielded pair. Steel or aluminum wire molding will be used wherever the cable cannot be concealed.

Maintenance and repair of this paging system will be the responsibility of the LESSOR.

NOTE: The total number of speakers required should be based on providing one speaker for every 300 square feet of area provided under this project.

VOICE AND DATA REQUIREMENTS SUMMARY

The LESSOR and/or the designated subcontractor(s) will be responsible for all voice and data cable facilities and materials within the building, with the exception of the telephone system and data equipment system. The installation must result in a "turnkey" solution to include: installation of all necessary equipment, paging system, cabling, cross-connects, patch cords, and test results. Any alarm system that is installed must have their own separate telephone service provided by the LESSOR.

A minimum of four zones will be accessible from any designated telephone. One zone will be established as “all call.” Other zones and speaker placements will be designated by the Office Manager. Wall mounted volume controls will be installed in conference, multipurpose, staff, and instructional rooms. Maintenance and repair of the intercom paging system will be the responsibility of the LESSOR.

CABLE RECORD

The LESSOR will prepare a cable record, which will include a copy of the floor plan (showing jacks locations, and numbering sequence), which coincides with the patch panel port labeling. A copy of the plan will be provided to the Office Manager at the time of final acceptance of the facility. Cable records will follow ANSI/TIA/EIA-606 standards.

CABLE CERTIFICATION TESTING

All test results will be provided to the Telecommunications Office or Office Manager prior to or at the time of final acceptance of the facility. Test results will be in numerical sequence. Voice and Data will be under separate cover. All testing will follow ANSI/TIA/EIA-568 standards. At a minimum the test results for each jack must include the following:

- Jack Number
- Cable Length
- Wire Map
- Attenuation
- NEXT (Near End Cross Talk)
- Cable Impedance

SECTION L. JANITORIAL SCHEDULE

	Daily	Weekly	Monthly	Quarterly	Semi-Annually	Annually	As Needed
GENERAL OFFICE CLEANING							
1. Empty all waste receptacles including trash cans and recycling containers. Replace plastic liners. Remove trash to designated, sanitary area.	X						
2. Clean all trash receptacles and recycling receptacles inside and out with a disinfectant. Replace trash cans and/or recycling containers if they become unusable.					X		X
3. Maintain separation and removal of recyclables in accordance with local ordinance or code.	X						
4. Empty and clean LESSOR provided cigarette urns.	X						
5. Clean water coolers. If included in the LEASE, ensure paper cups are restocked and a supply is available to the LESSEE.	X						
6. Thoroughly clean entrance doors		X					
7. Clean window glass on inside and outside of entrance doors.	X						
8. Wipe down weather mats. Notify LESSOR of torn or unsafe weather mats.	X						
9. Dust woodwork, files, bookcases, partitions, ledges, window sills, desks and work stations and other office furniture and equipment.		X					
10. Clean passenger elevator walls.		X					
11. Dust venetian blinds with treated cloth.				X			
12. Vacuum upholstered furniture.					X		
13. Wash all window glass inside and out.						X	
14. Wash venetian blinds.						X	
15. Dust all grills, vents, louvers and diffusers.			X				
16. Wash all grills, vents, louvers, diffusers and fluorescent lights and covers.						X	
17. Wash all doors and door knobs.		X			X		
18. Spot clean doors, door handles and other metal surfaces.			X				X

	Daily	Weekly	Monthly	Quarterly	Semi-Annually	Annually	As Needed
RESTROOM CLEANING							
1. Wash sinks, urinals, and toilet bowls using scouring powder to remove stains, clean under sides, wash both sides of toilet seats and tile walls near urinals with disinfectant.	X						
2. Empty, clean and reline all sanitary napkin receptacles.	X						
3. Fill and maintain mechanical operation of all toilet tissue dispensers, sanitary napkin dispensers, paper towel dispensers, soap dispensers and paper cup dispensers with LESSOR provided supplies. Ensure that replacement supplies are available to LESSEE.	X						
4. Polish flushmaster, piping, toilet hinges, dispensers, and other metal work in rest rooms.		X					
5. Clean shower stalls, if applicable.		X					
6. Wash doors, door handles, tile walls, stall partitions and fixtures with disinfectant.		X					
7. Clean mirrors	X						
OFFICE FLOORS							
1. Sweep and wet mop tile floors in kitchen, bathrooms, elevators and any general work areas.	X						
2. Sweep floors and stairs in stair wells.	X						
3. Spot clean carpets or tile floors including stair wells and elevators.		X					
4. Apply nonskid wax and buff tile floors.							X
5. Strip all tile floors of old finish and apply two coats of antiskid wax and buff.					X		
6. Steam clean carpeting in high traffic areas identified in No. 1 above.				X			

	Daily	Weekly	Monthly	Quarterly	Semi-Annually	Annually	As Needed
7. Steam clean carpeting in low traffic areas identified in No. 3 above.					X		
8. Vacuum all offices, hallways general work areas and any other carpeted areas.	X						
9. HEPA vacuum all offices.					X		
KITCHEN CLEANING							
1. Wash all counter surfaces, sinks, and table tops with antibacterial disinfectant.	X						
2. Wipe the refrigerator and microwave doors with a damp cloth and disinfectant.	X						
3. Clean the interior of the refrigerator and microwaves removing any spills, stains, etc.		X					
4. Clean kitchen cabinets inside and out. Wipe down outside of cabinets with a damp cloth and a disinfectant.					X		
OFFICE WALLS AND CLEANING							
1. Dust all ceilings and light fixtures.				X			
2. Remove and dust pictures, charts, etc from walls. Dust walls and re-hang pictures.					X		
3. Remove and clean pictures, charts, etc from walls. Wash walls and woodwork. Re-hang pictures						X	
4. Spot clean walls and woodwork. Ensure stained ceiling tiles are replaced as soon as possible.							X
OTHER CLEANING							
1. Clean janitor's sink and neatly store cleaning equipment and supplies in designated locations.	X						
2. Replace burned out bulbs in light fixtures with LESSOR provided light bulbs.							X

SECTION M. DIAGRAMS

DIAGRAM #1. TYPICAL RECEPTION AREA

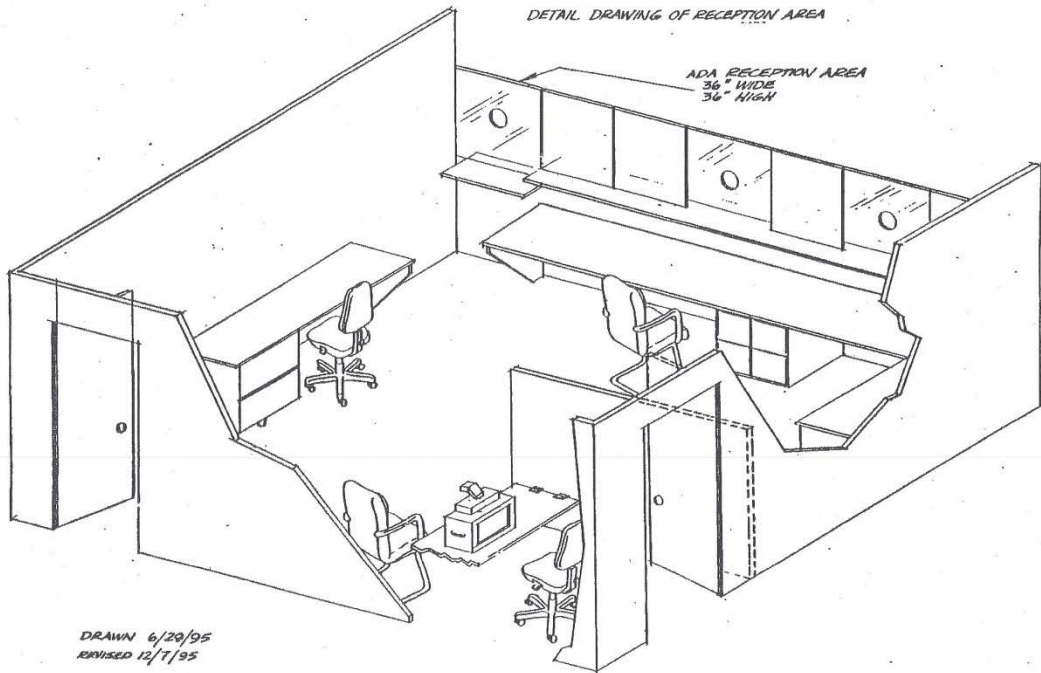

57

DIAGRAM #3. TYPICAL RECEPTION AREA - TOP VIEW

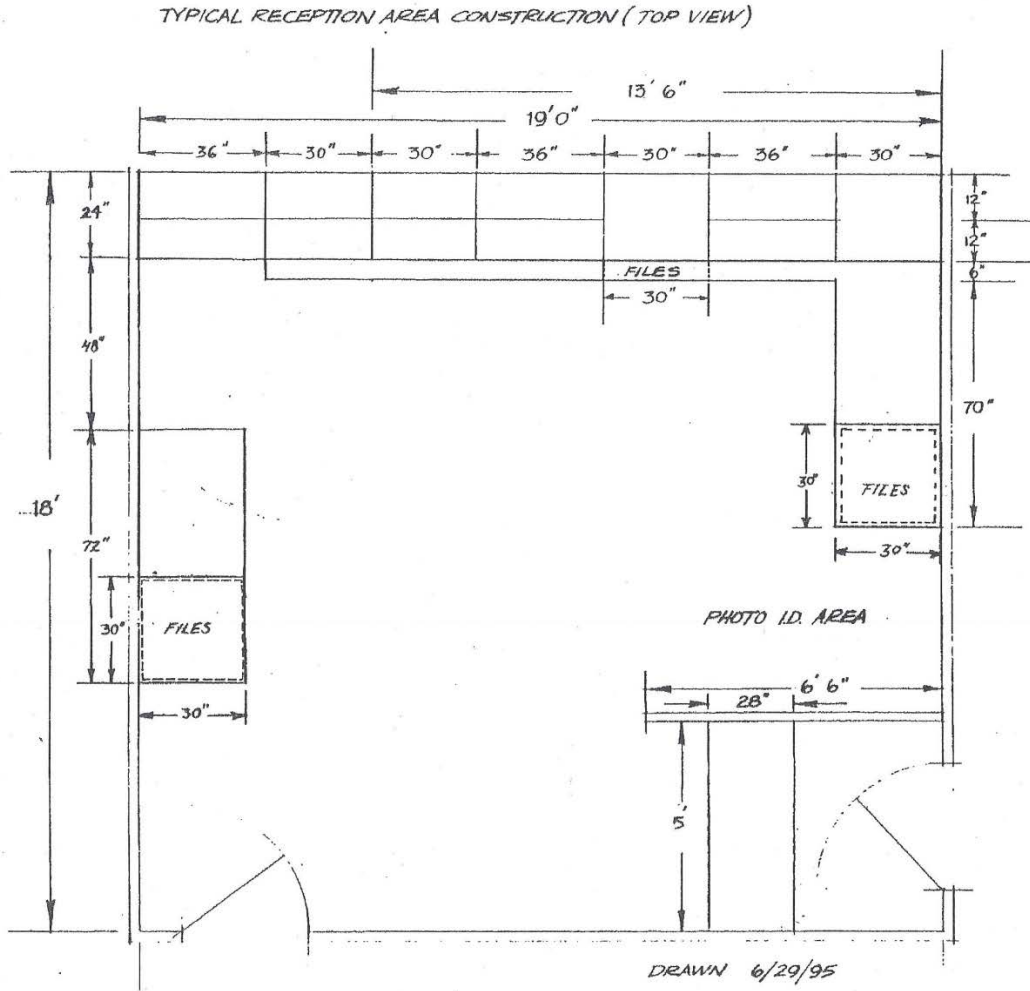
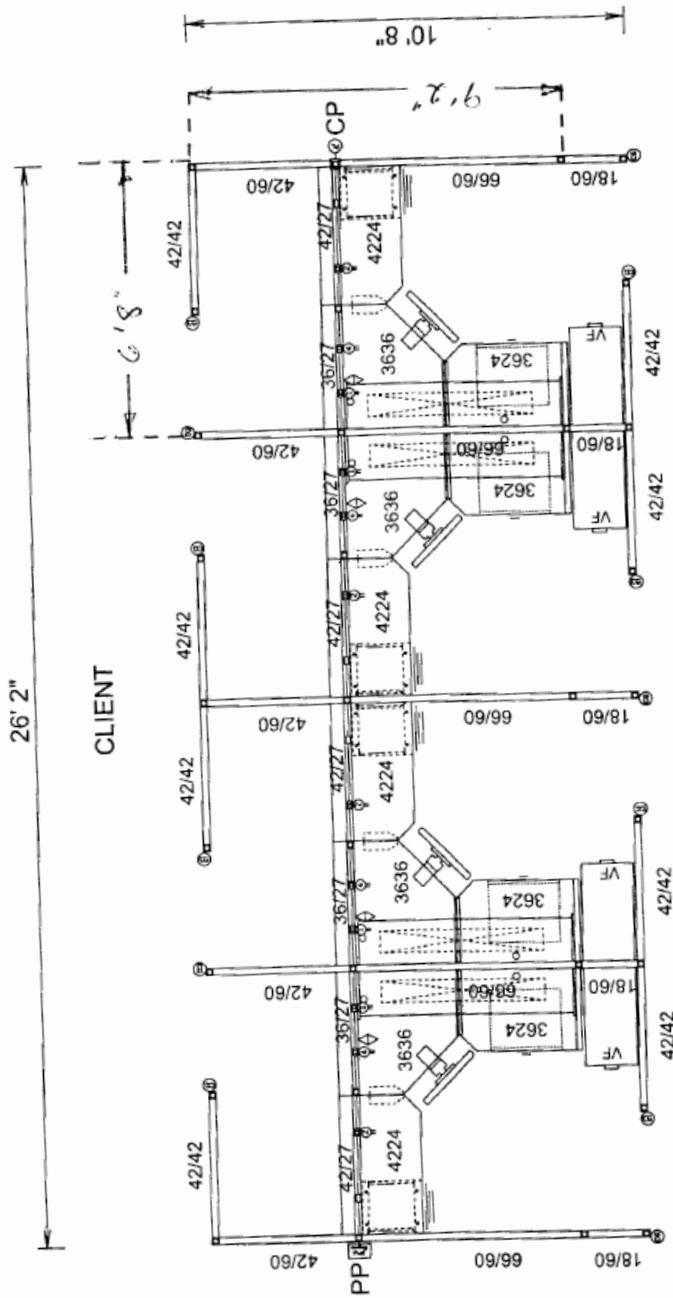

DIAGRAM #4. CUSTOMER SERVICE REPRESENTATIVES

NOT APPLICABLE

DIAGRAM #5. INTERVIEW BOOTH

PA Dept. of Public Welfare
 Typical 4 Cluster Intake-Interview Booth



- ◇ = DPW Data punch (1 per station)
 - CP = Com Pole
 - PP = Power Pole
 - All raceway covers on CLIENT side must be blank
- 1/4/07
 SOF988
 1/4"=1'

DIAGRAM #6. TYPICAL JUDGE'S BENCH AND WITNESS STAND

Not Applicable

DIAGRAM #7. JUDGE'S BENCH – TOP VIEW

Not Applicable

DIAGRAM #8. JUDGE'S BENCH – REAR VIEW

Not Applicable

DIAGRAM #9. JUDGE'S BENCH – ISOMETRIC VIEW

Not Applicable

DIAGRAM #10. TYPICAL WORKSTATIONS

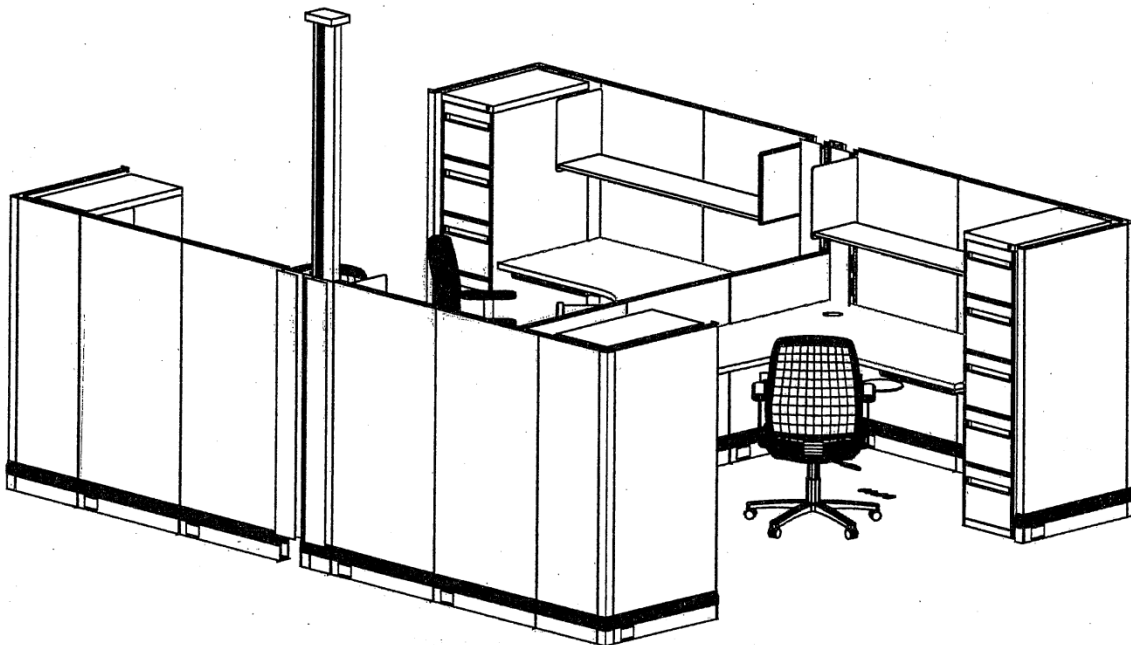
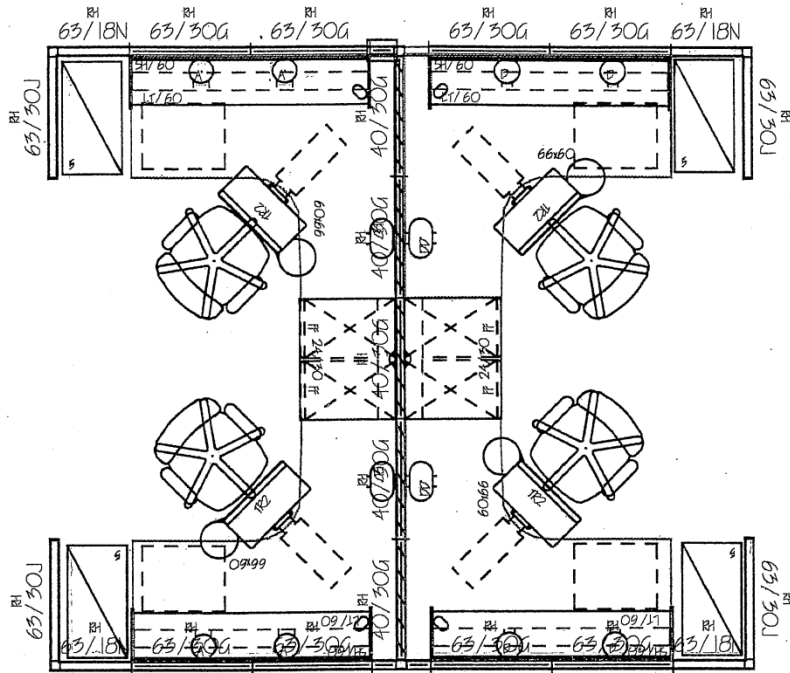
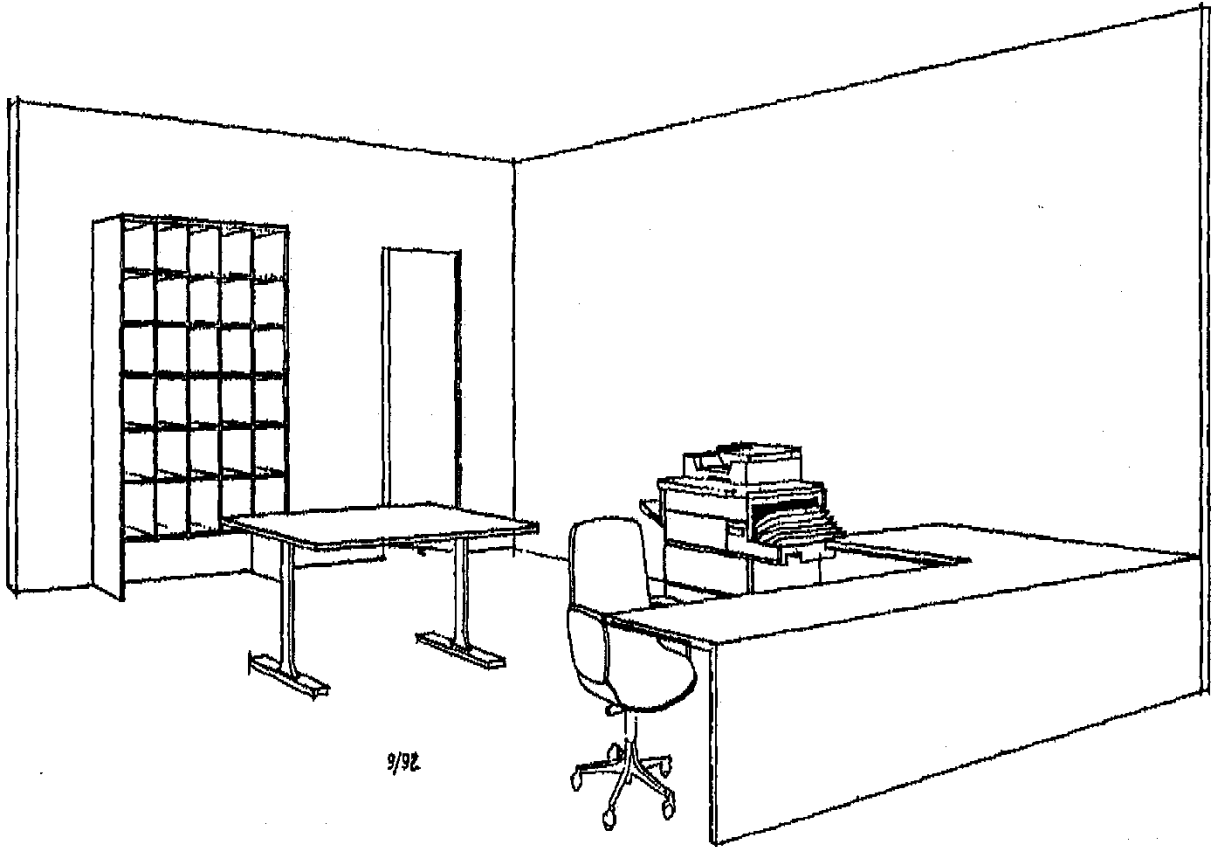

DIAGRAM #12. MAIL HANDLING AREA



9/92

MAIL HANDLING FACILITY

DIAGRAM #13. MAIL DISTRIBUTION UNIT

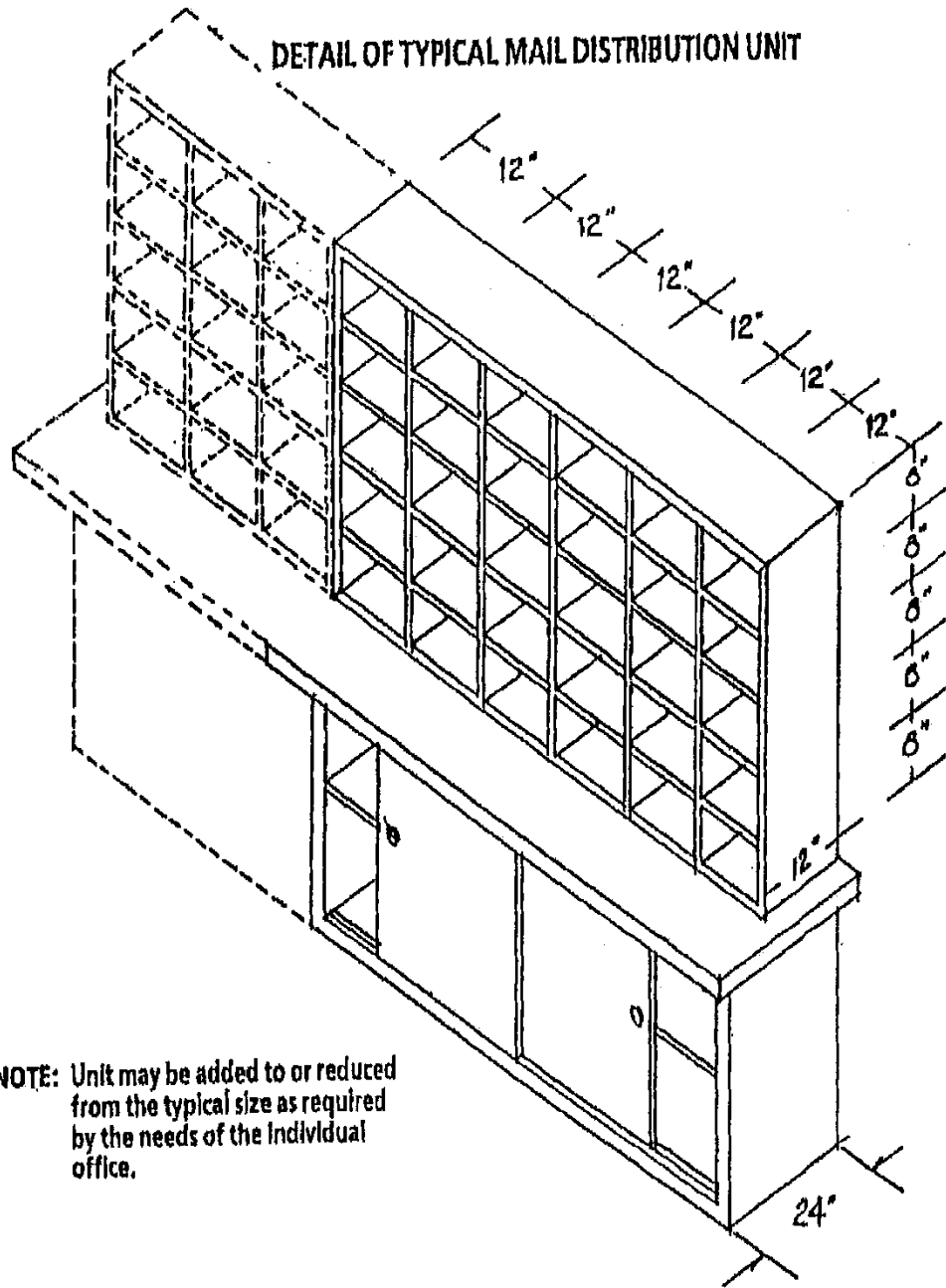

NOTE: Unit may be added to or reduced from the typical size as required by the needs of the individual office.

DIAGRAM #14. BUILDING IDENTIFICATION

This office must be identified with an appropriate building sign. DHS will provide specifications prior to construction.

APPENDIX D

**COMMONWEALTH OF PENNSYLVANIA
REQUIREMENTS**

APPENDIX D

Commonwealth of Pennsylvania Specifications and Requirements Package

NORMAL HOURS:

Services, Utilities and Maintenance will be provided daily, 7 days a week, 24 hour access and use of the premises and lease amenities as necessary.

The Commonwealth shall have access to the leased space at all times, including, but not limited to, the use of elevators, toilets, lights and operation of business machines without additional payment.

PARKING REQUIRED:

The minimum number of parking spaces must be included in your proposal . When the Local code requirement for parking to sq. ft. ratio of parking spaces available on site indicates that the Commonwealth is entitled to more spaces than the specified minimum, then those additional spaces shall at the Commonwealth option be added to the above stated minimum.

CODE AND/OR REGULATIONS CHANGES OR VIOLATIONS:

When changes occur in Local, State or Federal codes or regulations and the Lessor is required to take action or equipment services or utilities furnished and activities of other occupants are not free of Safety, Health or Fire hazards the Lessor shall promptly take action to comply with code or regulation requirements at his sole expense.

LANDSCAPE MAINTENANCE:

Landscape maintenance is to be performed during the growing season on a weekly cycle and will consist of the following:

Watering, mowing and policing area to keep it free of debris.

Pruning and fertilization are to be done on an as needed basis. In addition, dead or dying plants are to be replaced.

SECURITY:

The Lessor shall provide security comparable to the types of protection given similar enterprises to prevent illegal entry or loitering in the space leased and to prevent unauthorized entry during off-duty hours.

MORE OR LESS USABLE AREA:

The Commonwealth shall receive any useable area within the leased premises in excess of that requested free of any and all costs or charges.

In the event there is less space than that requested the Commonwealth shall pay only for the useable area provided and/or shall have the option to exercise its rights under the lease if it deems, in its sole judgment, that the amount of space being provided is insufficient to meet its needs.

ADJUSTMENT FOR VACANT SPACE:

If the Commonwealth fails to occupy any portion of the leased premises or vacates the premises in whole or in part prior to expiration of the firm term of the lease, the rental rate shall be reduced as follows:

The rate shall be reduced by that portion of the costs per square foot of operating expenses not required to maintain the space. Said reduction shall occur after the Commonwealth gives 30 days prior notice to the Lessor, and shall continue in effect until the Commonwealth occupies the premises or the lease expires or is terminated.

Exercise of this right by the Commonwealth shall not preclude it from any other options or rights it may have under the lease.

APPENDIX E

GEOGRAPHIC BOUNDARIES

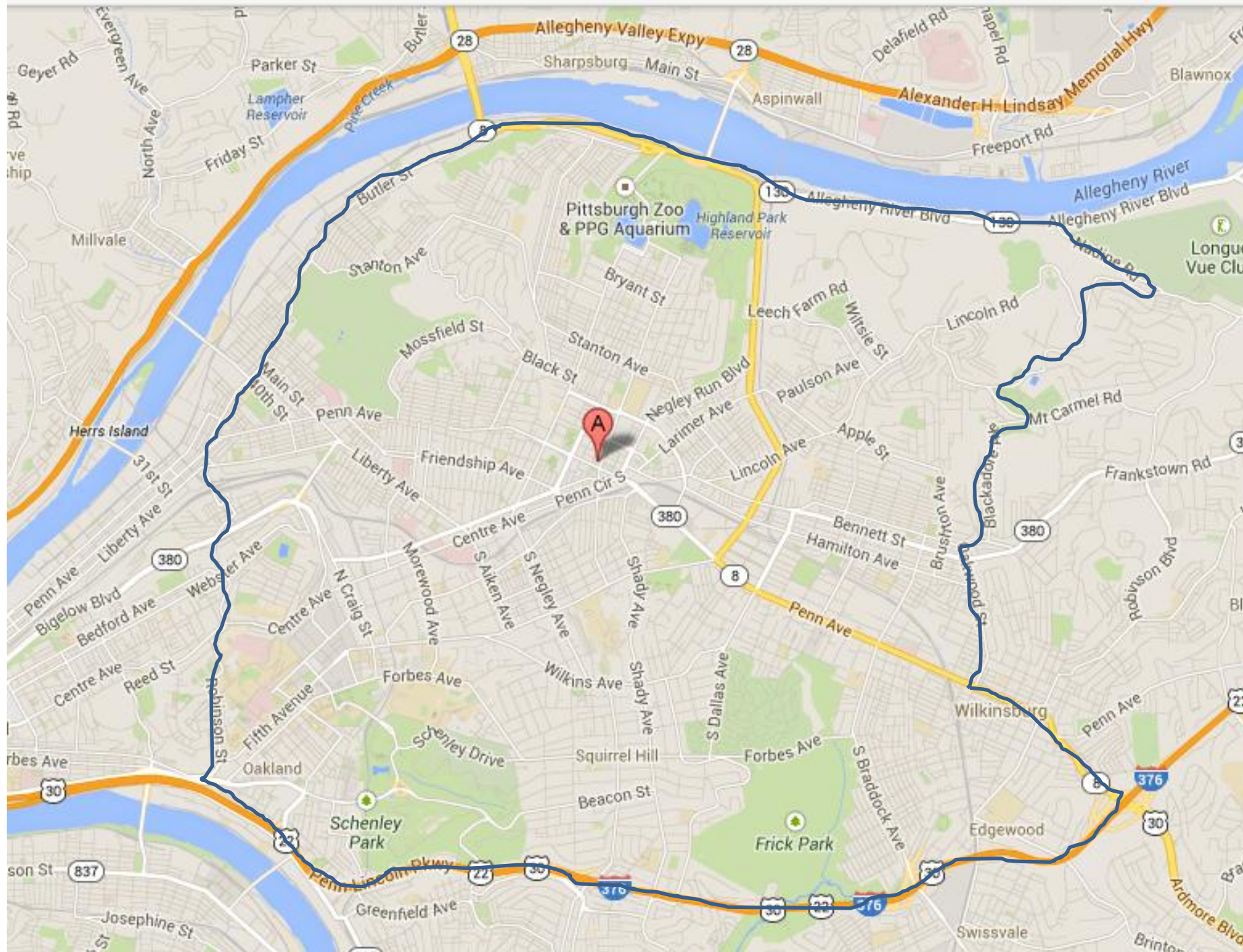

Allegheny GPE Lease Solicitation Geographic Boundaries

Northern boundary is the river

Butler Street at Route 8
Butler Street to Heron Ave
Heron Ave to Robinson St Ext/Robinson St
Robinson St to Route 30

Route 30/I-376 is the South boundary

Route 30/I-376 to Route 8
Route 8 to Wood St
Wood St/Oakwood St to Blackadore Ave
Blackadore Ave to Mt Carmel Rd
Mt Carmel Rd to Tyler Rd
Tyler Rd to Lincoln Rd
Lincoln Rd to Nadine Rd
Nadine Rd to Allegheny River Blvd